

FEATURES

1. Wide input voltage range (2:1)
2. High efficiency up to 92%
3. I/O isolation test voltage 1.5k VDC
4. Input under-voltage protection, output short-circuit, over-current, over-voltage, over-temperature protection
5. Operating ambient temperature range -40°C to +85°C
6. International standard pin mode
7. International standard 1/8 brick



3 years Warranty

Selection Guide

Product Model	Input Voltage (Range) VDC	Output Voltage VDC	Output Current @ Full Load mA	Output Efficiency Min/Typ %	Capacitive Load (Max) μF
GT4805EBO-75WR3	48VDC (36~75VDC)	5	15000	92	10000
GT4805EBO-75WIR3		5	15000	92	10000
GT4812EBO-75WR3		12	6250	92	4000
GT4812EBO-75WIR3		12	6250	91	4000
GT4848EBO-75WR3		48	1500	90	100
GT4848EBO-75WIR3		48	1500	90	100

Input Specifications

Parameter	Condition	Min	Typ	Max	Unit	
Input Current	Full load(V _{imin} , V _{onom} , I _{onom})	5V output	-	-	2600	mA
		12V output	-	-	2500	
	Unloaded (V _{onom} , I _o =0A)	5V output	-	-	120	
		12V output	-	-	100	
	Static state(V _{inom} , CNT turns off the output)	-	-	10		
Surge Voltage	36 to 75VDC Input series	-	-	80	VDC	
Start-up Voltage	36 to 75VDC Input series	-	-	36		
Under-voltage Protection		31	33	-		
Start-up Time	Nominal input voltage and constant resistance load	5V output	-	12	30	ms
		12V output	-	15	25	
		48V output	-	10	-	
Hot Plug		Unavailable				
CNT logic control	Low level	5V/12V output	-0.7	-	1.5	VDC
		48V output	-0.7	-	1.2	
	High level	3.5	-	20		
	Remote control current	-	-	2	mA	

Output Specifications

Parameter	Condition	Min	Typ	Max	Unit	
Line Regulation	Rated load	5V/48V output	-	±0.2	±0.5	%Vo
		12V output	-	±0.2	±0.4	
Load Regulation	Vin=48V; Io=0~Inom; TA = 25 °C	5V output	-	±0.5	±1	
		12V output	-	±0.3	±0.5	
		48V output	-	±0.5	±1.5	
Transient Recovery Time	25% load step change, nominal input voltage	5V/12V output	-	200	-	
		48V output	-	250	-	
Transient Response Deviation	25% load step change, nominal input voltage	5V/12V output	-	-	±5	%
		48V output	-	-	±4	
Temperature Coefficient	Full load	-	-	±0.02	%/°C	
Ripple & Noise ^①	The output is connected with 10µF tantalum capacitor and 1µF ceramic capacitor. The output capacitance is 50mm to 70mm away from the module pin. When Ta<-5 °C, it is recommended to add a 220, µF electrolytic capacitor (ESR≤100 mΩ)	5V output	-	70	100	mVp-p
		12V output	-	50	100	
		48V output	-	120	180	
Trim	Input voltage range	5V/48V output	-20	-	+10	%
		12V output	-10	-	+10	
Over-current Protection	Input voltage range	5V output	115	127	153	%Io
		12V output	120	-	160	
		48V output	-	193	-	
Over-voltage Protection	Input voltage range	5V output	115	120	124	%Vo
		12V output	115	-	127	
		48V output	-	117	-	
Short-circuit Protection	Short-circuit fault removal is self-restoring	Sustainable, self-healing				
Over-temperature protection	Close output (self-recovery)	5V/12V output	110	120	130	°C
		48V output	-	125	-	
	Return difference	-	20	-		

General Specifications

Parameter	Condition	Min	Typ	Max	Unit
Isolation Voltage	Input-output, leakage current less than 1mA, test time 1 minute	1500	-	-	VDC
Operating Temperature		-40	-	+85	°C
Storage Temperature		-55	-	+125	
Storage Humidity	Non-condensing	5	-	95	%RH
Pin Soldering Resistance Temperature	Wave soldering (welding time: 5~10s)	-	-	+260	°C
	Manual welding (welding time: 3~5s)	-	-	+425	
Switching Frequency		-	300	-	kHz
MTBF	Ta=25°C, Telcordia SR-332	-	2000	-	K hours

Mechanical Specifications

Size	No heat sink	57.94mm × 22.81mm × 9.80mm
	With type I heat sink	57.94mm × 22.81mm × 12.70mm
Weight	No heat sink	20.0g(Typ.)
	With type I heat sink	40.0g(Typ.)

Characteristic Curves

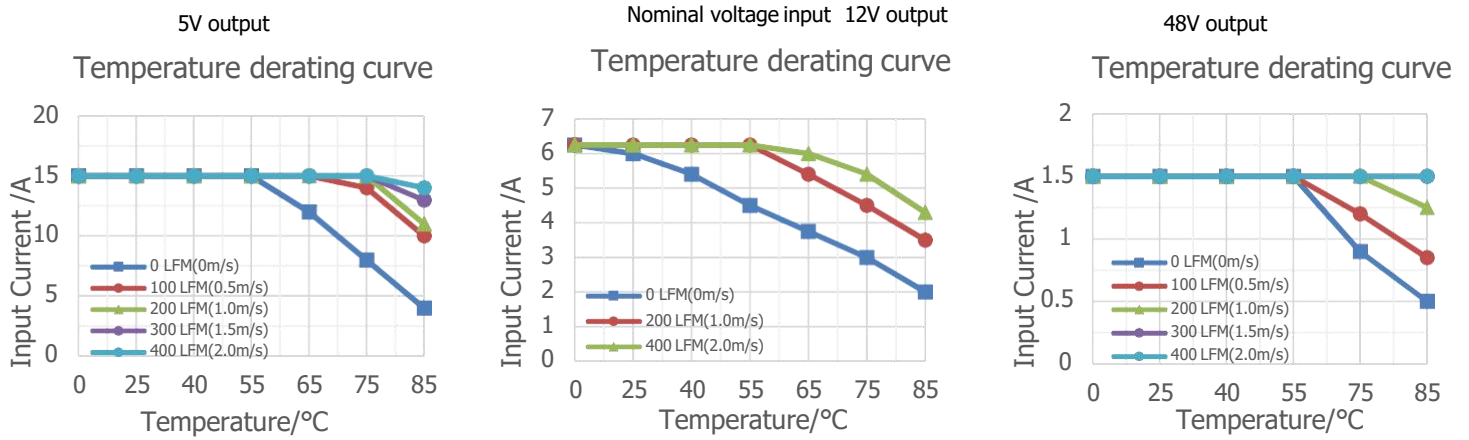

Figure 1

Design References

1. Application circuit

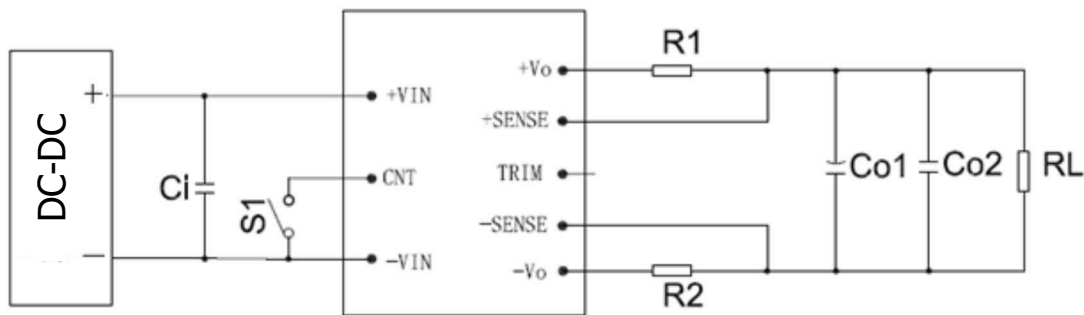

Figure 2

Vout (VDC)	Ci	Co1	Co2
5	100μF/100V	470μF/25V	1μF/25V
12		220μF/25V	
48		10μF/25V	

Note: 1. R1 and R2 are the equivalent resistors on the output line.

2. The output can be connected to the appropriate amount of electrolytic capacitors according to customer demand, but the maximum capacity of each channel cannot exceed 1000uF;

3. This model is a negative logic control, that is, the S1 switch is short-circuited for normal power output, and the S1 switch is disconnected for output off.

Dimensions and Recommended Layout

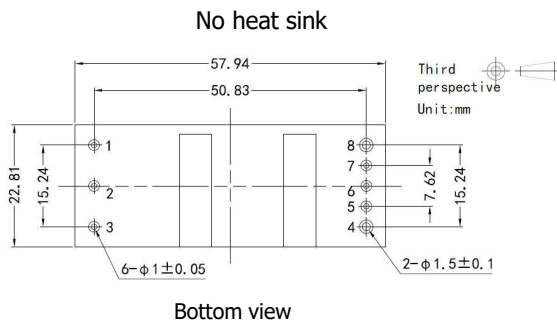

Side view

Figure 3

Note:

Size unit: mm

Terminal diameter tolerance: $\pm 0.10\text{mm}$

Unmarked tolerance: $\pm 0.50\text{mm}$

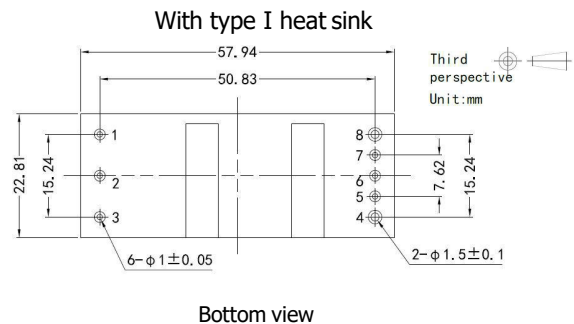

Side view

Figure 4

Pin definition

Pin	Mark	Implication
1	-Vin	Input negative
2	CNT	Remote control foot
3	+Vin	Input positive
4	+Vo	Output positive
5	+SENSE	Positive remote control terminal
6	Trim	Voltage regulating terminal
7	-SENSE	Negative remote control terminal
8	-Vo	Output minus

Note: The positioning holes on the aluminum baseplate are $\varnothing 3\text{mm}$. It is recommended that the screw length be locked into the power supply not more than 2mm.

Note:

1. If the product works under the minimum required load, it cannot guarantee that the performance of the product complies with all the performance indicators in this manual;
2. The maximum capacitive load is tested under the input voltage range and full load condition;
3. Unless otherwise stated, all indexes in this manual are measured at $T_a=25^\circ\text{C}$, humidity $<75\%\text{RH}$, nominal input voltage and rated output load;
4. All index testing methods in this manual are based on the enterprise standards of the company;
5. Our company can provide product customization, specific needs can directly contact our technical staff;