

## Product Feature

1. Package Type: SIP8
2. Operating Temperature Range: -40°C - +85°C
3. Isolation Voltage: 1500VDC
4. 2:1 Wide Input Voltage Range
5. High efficiency up to 88%
6. With the input undervoltage protection, output short circuit protection and output overcurrent protection mechanism
7. Fields of application: industry, industrial control, instrumentation, communication, rail transit, etc

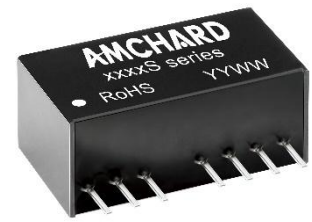

3 years Warranty

## Selection Guide

Part No.	Input Voltage (VDC)		Output		Full Load Efficiency% (Min./Typ.)	Capacitive Load Max. (µF)
	Nominal (Range)	Maximum	Voltage (VDC)	Current Max.(mA)		
GTB1203S-10WR3	12 (9-18)	20	3.3	2400/0	81/83	2200
GTB1205S-10WR3			5	2000/0	84/86	2200
GTB1209S-10WR3			9	1111/0	84/86	680
GTB1212S-10WR3			12	833/0	84/86	470
GTB1215S-10WR3			15	667/0	84/86	330
GTB1224S-10WR3			24	417/0	84/86	220
GTB2403S-10WR3	24 (18-36)	40	3.3	2400/0	83/85	2200
GTB2405S-10WR3			5	2000/0	86/88	2200
GTB2409S-10WR3			9	1111/0	86/88	680
GTB2412S-10WR3			12	833/0	86/88	470
GTB2415S-10WR3			15	667/0	86/88	330
GTB2424S-10WR3			24	417/0	86/88	220

## Input Specifications

Item	Operating Conditions		Min.	Typ.	Max.	Unit
Input Current (full load/no load)	12VDC nominal input series, nominal input voltage	3.3VDC Output	--	777/35	796/50	mA
		5VDC Output	--	969/35	992/50	
		Other Output	--	969/9	992/18	
	24VDC nominal input series, nominal input voltage	3.3VDC Output	--	389/25	398/45	
		5VDC Output	--	474/25	485/45	
		Other Output	--	474/9	485/18	
Reflected Ripple Current			--	50	--	
Impulse Voltage	12VDC Nominal Input Series		-0.7	--	25	VDC
	24VDC Nominal Input Series		-0.7	--	50	

Starting Voltage	12VDC Nominal Input Series	--	--	9
	24VDC Nominal Input Series	--	--	18
Input Undervoltage Protection	12VDC Nominal Input Series	5.5	6.5	--
	24VDC Nominal Input Series	12	15.5	--
Input Filter	Capacitance Filter			
Hot Plug	Unavailable			
CTRL	Module off	0-1.2V turn off		
	Module on	No connect or 3.5-12V on		

## Output Specifications

Item	Operating Conditions	Min.	Typ.	Max.	Unit	
Output Voltage Accuracy	5% - 100% Load	--	±1.5	±2.0	%	
Linear Regulation	Full load, Input voltage from low limit to high limit	--	±0.25	±0.5		
Load Regulation	5% - 100% Load	--	±0.5	±1.0		
Transient Recovery Time	25% load step change	--	0.3	0.5	ms	
Transient Response Deviation		3.3VDC、5VDC Output	--	±5	±8	%
		Other Output	--	±3	±5	
Temperature Coefficient	Full Load	--	--	±0.03	%/°C	
Ripple & Noise	20MHZ Bandwidth,5% - 100% Load 5% - 100% Load	--	75	150	mVp-p	
Overcurrent Protection	Input Voltage Range	--	160	230	%Io	
Short-circuit Protection		Continuous, Self-Recovery				

## General Specifications

Item	Operating Conditions	Min.	Typ.	Max.	Unit
Insulation Voltage	Input-output, test time 1 minute, leakage current less than 1mA	1500	--	--	VDC
Insulation Resistance	Input-output, insulated voltage 500VDC	1000	--	--	MΩ
Isolation Capacitance	Input-output, 100KHz/0.1V	--	1000	--	pF
Operating Temperature	See Figure 1	-40	--	+85	°C
Storage Temperature		-55	--	+125	
Storage Humidity	Non-condensing	5	--	95	%RH
Pin welding can withstand the highest temperature	Soldering spot is 1.5mm away from case for 10 seconds	--	--	+300	°C
Switching Frequency	Full Load, Nominal Input Voltage	--	500	--	KHz
MTBF	MIL-HDBK-217F@25°C	>1000Kh			

### Mechanical Specifications

<b>Case Material</b>	Black plastic; flame-retardant and heat-resistant (UL 94V-0 rated)
<b>Package Dimensions</b>	22.00 * 9.50*12.00 mm
<b>Weight</b>	4.8g (Typ.)
<b>Cooling Method</b>	Free air convection

### EMC Specifications

<b>EMI</b>	CE	CISPR32/EN55032 CLASS B (The recommended circuit is shown in Figure 3-②)	
	RE	CISPR32/EN55032 CLASS B (The recommended circuit is shown in Figure 3-②)	
<b>EMS</b>	ESD	IEC/EN61000-4-2 Contact±4KV	perf.Criteria B
	RS	IEC/EN61000-4-3 10V/m	Perf.Criteria A
	EFT	IEC/EN61000-4-4 ±2KV (The recommended circuit is shown in Figure 3-①)	Perf.Criteria B
	Surge	IEC/EN61000-4-5 line to line±2KV (The recommended circuit is shown in Figure 3-①)	Perf.Criteria B
	Cs	IEC/EN61000-4-6 3 Vr.m.s	Perf.Criteria A

### Typical Characteristic Curves

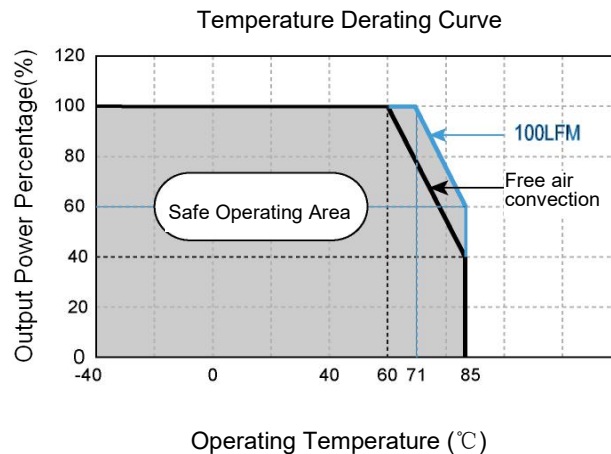
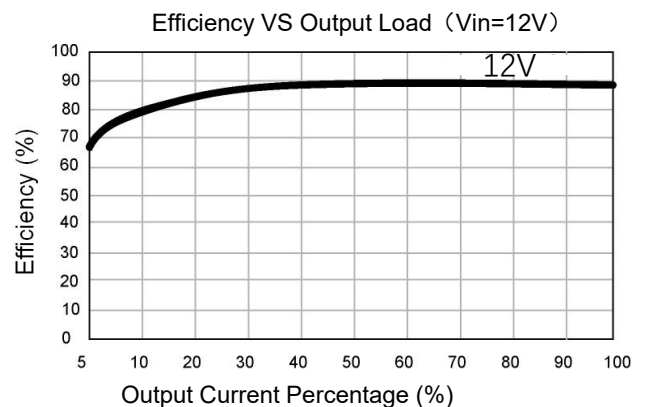
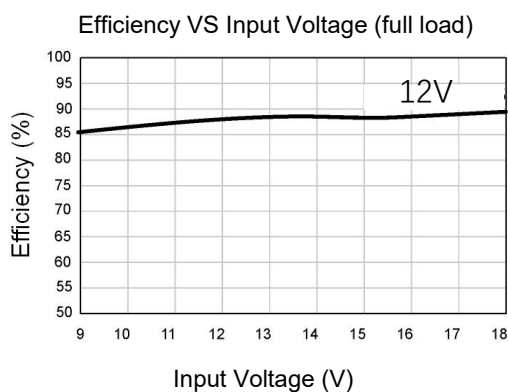
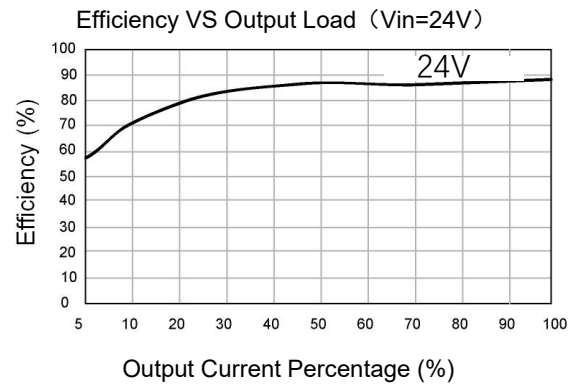
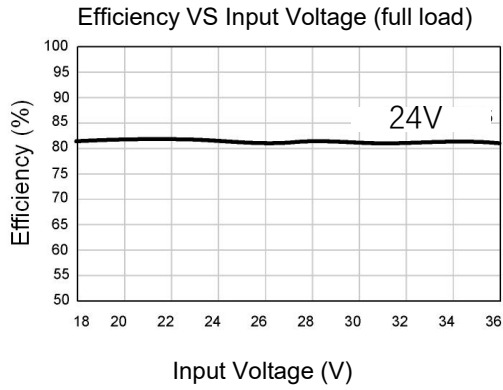

Figure 1





### Circuit Design and Application

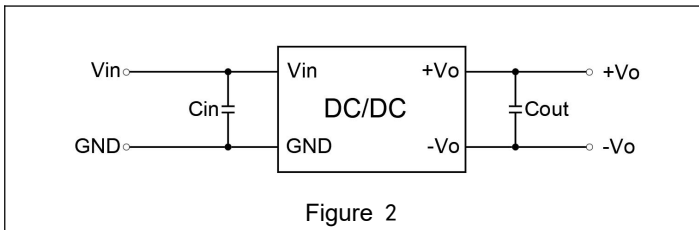

Figure 2

#### Recommended Capacitive Load Value Table

$C_{in}(\mu F)$	$C_{out}(\mu F)$
47	22

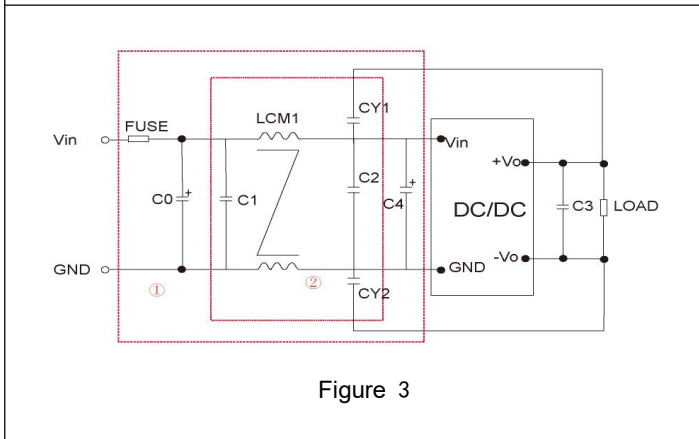

Figure 3

#### EMI Recommended Parameter Table

Model	$V_{in}:12V$	$V_{in}:24V$
FUSE	Select according to the actual input current of the customer	
$C_0$ 、 $C_4$	330 $\mu F/35V$	330 $\mu F/50V$
$C_1$ 、 $C_2$	10 $\mu F/50V$	
LCM1	470 $\mu H$	
$C_3$	Refer to the $C_{out}$ parameter in Figure 2	
$CY_1$ 、 $CY_2$	1nF/2000VDC	

Note: Part 1 in Figure 3 is for EMC testing; The second part is used for EMI filtering, which can be selected according to the demand

## Dimensions and Recommended Layout

Dimensions

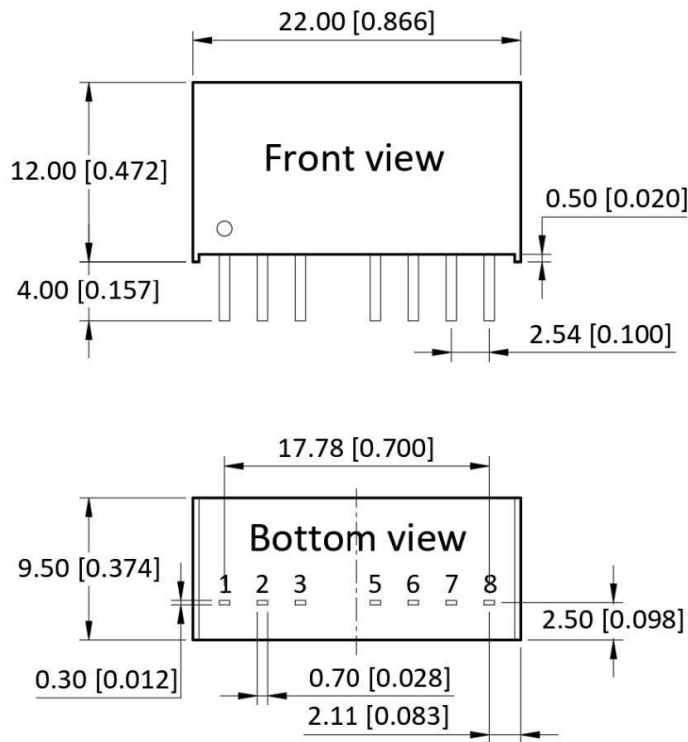

PCB Printing Layout & Pin Definition Table

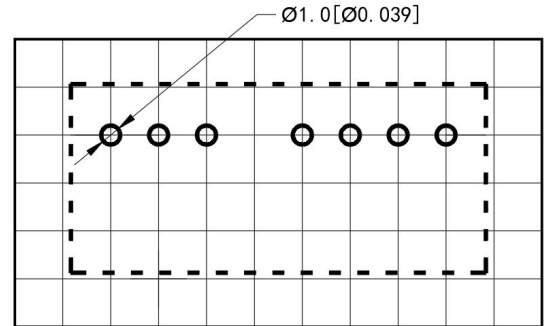

Note: The grid distance is 2.54mm\*2.54mm

Pin	Function (single)	Function (double)
1	GND	GND
2	Vin	Vin
3	CTRL	CTRL
5	NC	NC
6	+Vo	+Vo
7	-Vo	COM
8	NC	-Vo

NC: Pin to be isolated from circuitry

Note:

Unit: mm[inch]

Pin section tolerances: ±0.10 [±0.004]

General tolerances: ±0.50 [±0.020]

### Note:

1. The input voltage cannot exceed the specified range value, otherwise permanent and irreparable damage may be caused ;
2. Unless otherwise specified, the parameters in this datasheet were measured at 25°C, humidity 40%~75%, input nominal voltage and output pure resistance mode under full load;
3. All index test methods are based on our company's enterprise standards.