

## Product Feature

1. Package Type: 1"X 1"
2. Operating temperature range: -40°C - +105°C
3. Isolation voltage: 1500VDC
4. High efficiency up to 92%
5. The mechanism has input undervoltage protection, output short circuit protection and over current protection
6. 4:1 Ultra-wide input voltage range
7. Fields of application: Power, industrial control, communications, Internet of Things, automotive, etc



3 years Warranty

## Selection Guide

Part No.	Input Voltage (VDC)		Output		Full Load Efficiency% (Typ.)	Capacitive Load(μF) Max.
	Nominal (Range)	Maximum	Voltage (VDC)	Current (mA)		
ATB2403YMD-40WR3	24 (9-36)	40	3.3	10000/0	89	10000
ATB2405YMD-40WR3			5	8000/0	91	10000
ATB2412YMD-40WR3			12	3333/0	91	2700
ATB2415YMD-40WR3			15	2667/0	92	1680
ATB2424YMD-40WR3			24	1667/0	91	680
ATB4803YMD-40WR3	48 (18-75)	80	3.3	8000/0	89	10000
ATB4805YMD-40WR3			5	8000/0	91	10000
ATB4812YMD-40WR3			12	3333/0	92	2700
ATB4815YMD-40WR3			15	2667/0	92	1680
ATB4824YMD-40WR3			24	1667/0	91	680
ATB4828YMD-40WR3			28	1428/0	91	680

## Input Specifications

Item	Operating Conditions	Min.	Typ.	Max.	Unit
Input Current (full load/no-load)	24VDCnominal input series	3.3VDC	--	1894/60	1938/100
		5VDC output	--	1852/60	1894/100
		Other	--	1852/12	1894/25
	48VDCnominal input series	3.3VDC	--	958/60	998/100
		5VDC output	--	926/60	958/100
		Other	--	926/12	947/25
Reflected Ripple Current	nominal input	--	60	--	
Impulse Voltage	24VDCnominal input series	-0.7	--	50	VDC
	48VDCnominal input series	-0.7	--	100	
Starting Voltage	24VDCnominal input series	--	--	9	
	48VDCnominal input series	--	--	18	
Input undervoltage protection	24VDCnominal input series	5.5	7.5	--	
	48VDCnominal input series	12.0	15.5	--	
Ctrl	turn off module	connected GND or (0-1.2V)			
	turn on module	No connected or (3.5-12V)			

	Input current when off	--	5	8	mA
Input Filter		PI filter			

## Output Specifications

Item	Operating Conditions	Min.	Typ.	Max.	Unit
Output Voltage Accuracy	5%-100% load	--	±1.0	±3.0	%
Linear Regulation	Vin=Min. to Max. @Full Load	--	±0.2	±0.5	
Load Regulation	5%-100% load	--	±0.5	±1.0	
Ripple & Noise	20MHz bandwidth,5%-100% load	--	100	200	mVp-p
Transient Recovery Time	25% Load Step Change, nominal input voltage	--	300	500	µs
Transient Response Deviation		--	±5	±8	%
Temperature Coefficient	Full Load	--	±0.01	±0.02	%/°C
Trim	input voltage range	--	±10.0	--	%
Over Voltage Protection		110	140	--	%
Over Current Protection		110	140	--	%
Short-Circuit Protection		Continuous, Self-Recovery			

## General Specifications

Item	Operating Conditions	Min.	Typ.	Max.	Unit
Isolation Voltage	Input-output, test time 1 minute, leakage current less than 1mA	1500	--	--	VDC
Insulation Resistance	Input-output, insulated voltage 500VDC	1000	--	--	MΩ
Isolation Capacitance	Input-output, 100KHz/0.1V	--	2000	--	pF
Operating Temperature	See Fig 1, Fig 2	-40	--	+105	°C
Storage Temperature		-50	--	+125	
Storage Humidity	Non-condensing	--	--	95	%RH
Soldering Profile	1.5mm from case for 10 sec	--	--	300	°C
Switching Frequency	Full load, nominal input voltage	--	330	--	kHz
MTBF	MIL-HDBK-217F@25°C	1000	--	--	K Hours

## Mechanical Specifications

<b>Case Material</b>	Aluminum alloy
<b>Package Dimensions</b>	25.4mm * 25.40mm * 12.00 mm
<b>Weight</b>	21.00g(Typ.)
<b>Cooling Method</b>	Free air convection

## EMC Specifications

EMI	CE	EN55032, FCC part 15	CLASS B
	RE		
EMS	ESD	EN61000-4-2 Air ± 8kV , Contact ± 6kV	perf. Criteria B
	RS	EN61000-4-3 10V/m	perf. Criteria A
	EFT	EN61000-4-4 ±2kV	perf. Criteria B
	Surge	EN61000-4-5 ±1kV	perf. Criteria B
	CS	EN61000-4-6 3Vrms	perf. Criteria A

**Typical Characteristic Curves**

Temperature Derating (ATB2403/05YMD-40WR3)

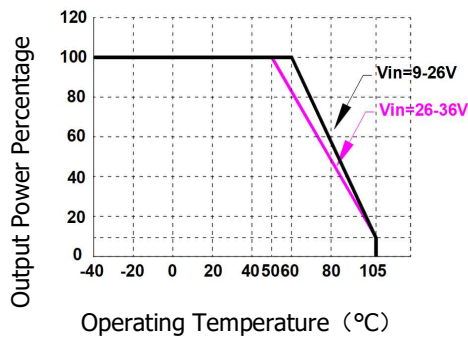

Fig 1-1

Temperature Derating (ATB2412/24YMD-40WR3)

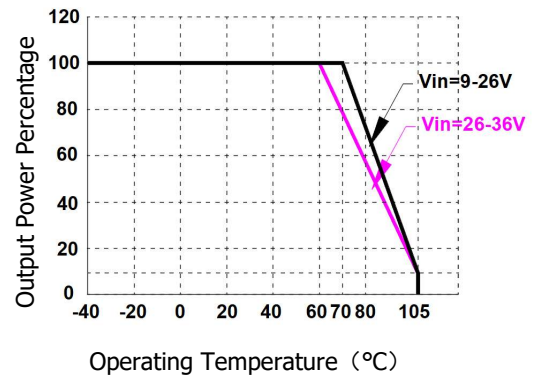

Fig 1-2

Temperature Derating (ATB4803/05YMD-40WR3)

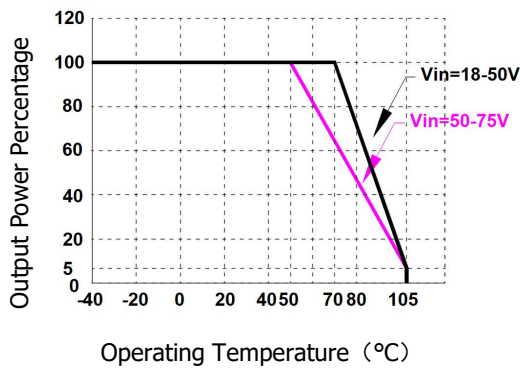

Fig 2-1

Temperature Derating (ATB4812/15YMD-40WR3)

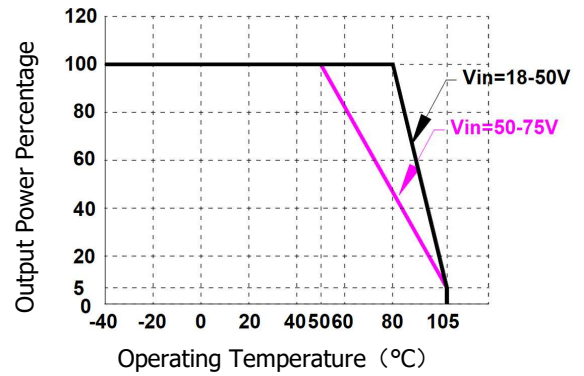
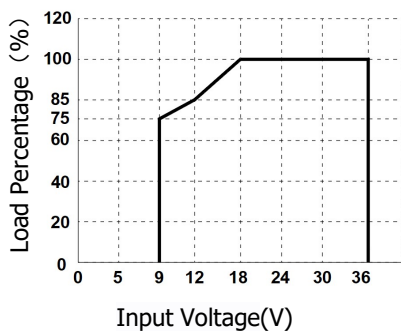
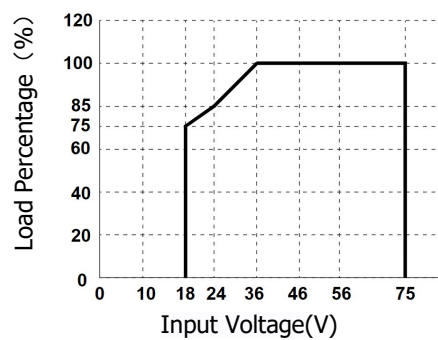

Fig 2-2

Load VS Vin (24V)



Load VS Vin (48V)



## Typical Circuit Design And Application

Fig 3

Recommended component parameters

Vin(VDC)	C1(uF)	C2(uF)	C3(uF)	C4(uF)
24	100	470	10	0.1
48			22	10

Fig 4

EMI recommended component parameters												
Vin (VDC)	FUSE	CEC1 (uF)	EC2 (uF)	C1,C2,C3, C4,C5,C6,	LCM1 (mH)	LDM1 (uH)	C8,C9 (uF)	CY2	CY1,C Y3	EC3 (uF)	C10 (uF)	C11 C12
24V	Choose according to actual input current	1000	220	4.7	0.32	2.2	-	222	2200	470	10	1uF
48V		680	100	4.7	10	6.8	4.7	102	2200	470	22	10uF

Trim up                      Trim down

Trim resistor connections (dashed line shows internal resistor network)

Trim

Vout(V)	R1(KΩ)	R2(KΩ)	R3(KΩ)	Vref(V)
3.3	10	6.064	13.622	1.24
5	2.4	2.344	13.622	2.5
12	8.2	2.153	17.346	2.5
15	12	2.388	21.016	2.5
24	10	1.158	10.714	2.5
28	10	0.979	13.04	2.5

Up:  $R_t = \frac{nR_2}{R_2 - n} - R_3$        $n = \frac{V_{ref}}{V_o - V_{ref}} * R_1$

Down:  $R_t = \frac{nR_1}{R_1 - n} - R_3$        $n = \frac{V_o - V_{ref}}{V_{ref}} * R_2$

All DC-DC converters of this series are tested before delivery using the recommended circuit shown in Fig. 2. Input and/or output ripple can be further reduced by appropriately increasing the input & output capacitor values  $C_{in}$  and  $C_{out}$  and/or by selecting capacitors with a low ESR (equivalent series resistance). Also make sure that the capacitance is not exceeding the specified max. capacitive load value of the product.

## Dimensions and Recommended Layout

### Dimensions

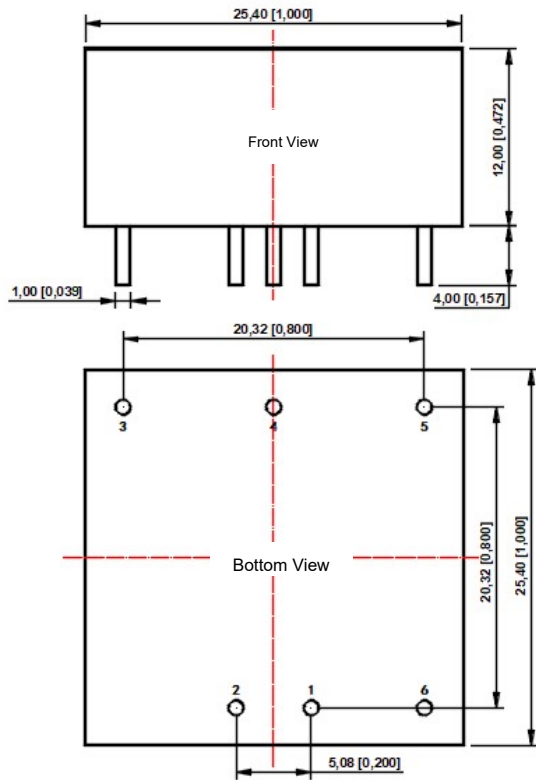

Note:  
Unit: mm[inch]  
Pin section tolerances:  $\pm 0.10 [\pm 0.004]$   
General tolerances:  $\pm 0.50 [\pm 0.020]$

### PCB Printing Layout & Pin Definition Table

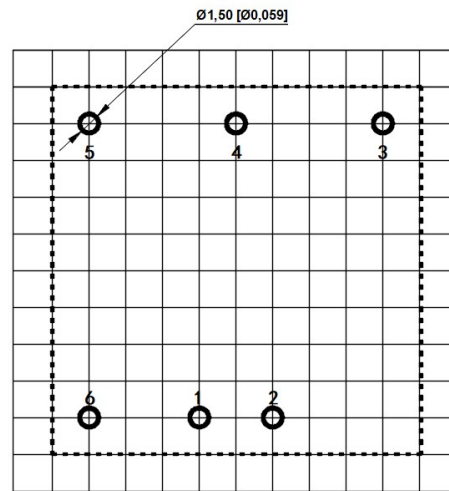

Note: The grid distance is 2.54\*2.54mm

Pin	Function
1	GND
2	Vin
3	+Vo
4	Trim
5	-Vo
6	Ctrl

### Note:

1. If the product works under the minimum required load, it cannot guarantee that the performance of the product complies with all the performance indicators in this manual;
2. The maximum capacitive load is tested under the input voltage range and full load condition;
3. Unless otherwise stated, all indexes in this manual are measured at  $T_a=25^\circ\text{C}$ , humidity  $<75\%RH$ , nominal input voltage and rated output load;
4. All index testing methods in this manual are based on the enterprise standards of the company;
5. Our company can provide product customization, specific needs can directly contact our technical staff;