

Product Feature

1. Package Type: 2"X 1"
2. Operating temperature range: -40°C - +105°C
3. Isolation voltage: 1600VDC
4. 4:1 Ultra-wide input voltage range
5. High efficiency up to 93%
6. The mechanism has input undervoltage protection, output short circuit protection and over current protection
7. Fields of application: Power, industrial control, communications, Internet of Things, automotive, etc



3 years Warranty

Selection Guide

Part No.	Input Voltage (VDC)		Output			Full Load Efficiency % (Typ.)	Capacitive Load(μF) Max.
	Nominal (Range)	Maximum	Voltage (VDC)	Current Min.(mA)	Current Max.(mA)		
ATB2405LD-60WR3(A2S)	24 (9-36)	40	5	0	12000	92	20000
ATB2406LD-60WR3(A2S)			6	0	10000	92	10000
ATB2412LD-60WR3(A2S)			12	0	5000	93	5000
ATB2415LD-60WR3(A2S)			15	0	4000	93	3500
ATB2424LD-60WR3(A2S)			24	0	2500	93	2000
ATB4805LD-60WR3(A2S)	48 (18-75)	80	5	0	12000	92	20000
ATB4806LD-60WR3(A2S)			6	0	10000	92	10000
ATB4812LD-60WR3(A2S)			12	0	5000	93	5000
ATB4815LD-60WR3(A2S)			15	0	4000	93	3500
ATB4824LD-60WR3(A2S)			24	0	2500	93	2000
ATB4828LD-60WR3(A2S)			28	0	2143	93	1500

Notes:

- ① Exceeding the maximum input voltage may cause permanent damage;
- ② Efficiency is measured at nominal input voltage and rated output load.

Input Specifications

Item	Operating Conditions	Min.	Typ.	Max.	Unit
Input Current(full load/no-load)		--	2717/25	2778/30	mA
Impulse Voltage		-0.7	--	50	VDC
Starting Voltage		--	--	9	
Input Filter		PI Filter			
Hot Plug		Unavailable			
Ctrl	turn off module	0 - 1.2V Turn Off			
	turn on module	No Connected or 3 - 12V Turn On			

Output Specifications

Item	Operating Conditions	Min.	Typ.	Max.	Unit	
Output Voltage Accuracy	5%-100% load	--	±1.0	±2.0	%	
Linear Regulation	Vin=Min. to Max. @Full Load	--	±0.2	±0.5		
Load Regulation	5%-100% load	--	±0.5	±1		
Transient Recovery Time	25% Load Step Change,nominal input voltage	--	250	500	µs	
Transient Response Deviation	25% step change , nominal input voltage	5VDC output	--	±3	±10	%
		Other output	--	±3	±5	
Ripple & Noise	20MHz bandwidth,5%-100% load	--	100	--	mVp-p	
Over Voltage Protection		110	160	160	%Vo	
Over Current Protection	input voltage range	110	160	230	%Io	
Short-Circuit Protection		Continuous, Self-Recovery				

General Specifications

Item	Operating Conditions	Min.	Typ.	Max.	Unit
Isolation Voltage	Input-output, test time 1 minute, leakage current less than 1mA	1600	--	--	VDC
Insulation Resistance	Input-output, insulated voltage 500VDC	1000	--	--	MΩ
Isolation Capacitance	Input-output, 100KHz/0.1V	--	2200	--	pF
Operating Temperature	See Figure 1	-40	--	105	°C
Storage Temperature		-55	--	125	
Storage Humidity	Non-condensing	5	--	95	%RH
Soldering Profile	1.5mm from case for 10 sec	--	--	300	°C
Switching Frequency	Full load, nominal input voltage	--	310	--	kHz
MTBF	MIL-HDBK-217F@25°C	>1000Kh			

Mechanical Specifications

Case Material	Aluminum alloy
Package Dimensions	50.80mm * 25.40mm * 11.80 mm
Weight	41.0g
Cooling Method	Free air convection

EMC Specifications

EMI	CE	CISPR32/EN55032	CLASS A/CLASS B
	RE		
EMS	ESD	EN61000-4-2 Air \pm 8kV , Contact \pm 6kV	perf. Criteria B
	RS	EN61000-4-3 10V/m	perf. Criteria A
	EFT	EN61000-4-4 \pm 2kV	perf. Criteria A
	Surge	EN61000-4-5 \pm 2kV	perf. Criteria A
	CS	EN61000-4-6 10Vrms	perf. Criteria A

Typical Characteristic Curves

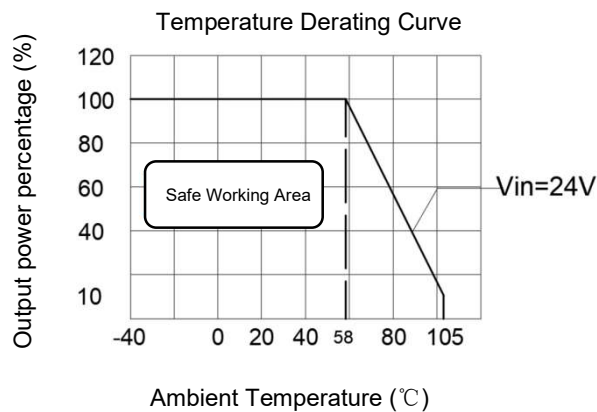
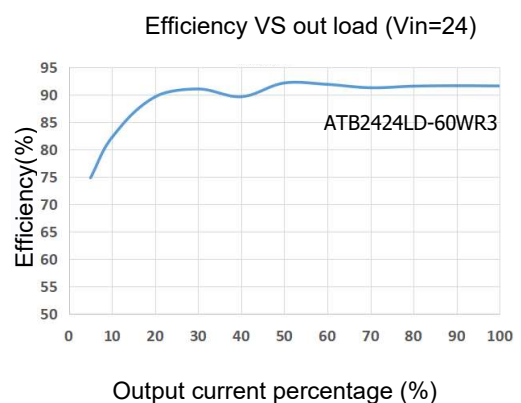
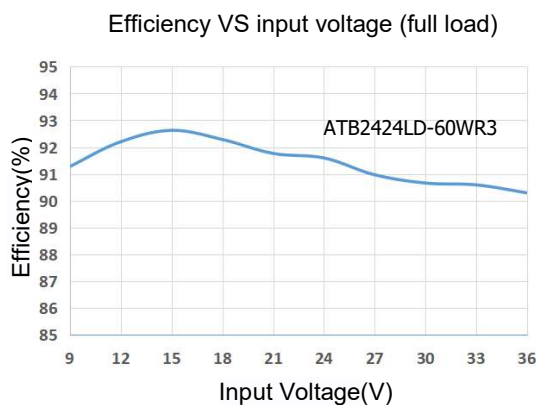

Figure 1

Typical Circuit Design And Application

Application circuit

All DC/DC converters of this series are tested in accordance with the test circuit recommended in FIG. 2 before delivery. If the input and output ripple is required to be further reduced, the input and output external capacitors C_{in} and C_{out} can be increased or a capacitor with a small series equivalent impedance value can be selected, but the capacitance value cannot be greater than the maximum capacitive load of the product.

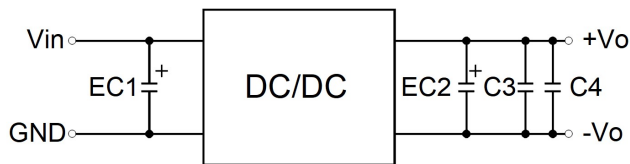

Figure 2

Vout(VDC)	EC1(uF)	EC2(uF)	C3(uF)	C4(uF)
5	100µF/50V	330µF/35V	10µF/16V	0.1µF/16V
12/15		150µF/35V	10µF/25V	0.1µF/25V
24		100µF/50V	10µF/50V	0.1µF/50V

EMS Solutions - Recommended Circuits

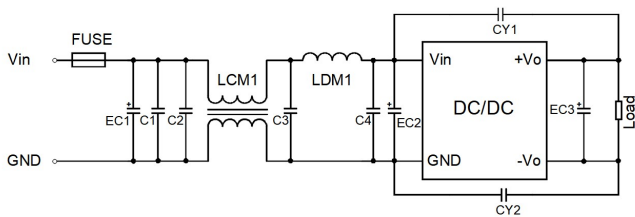
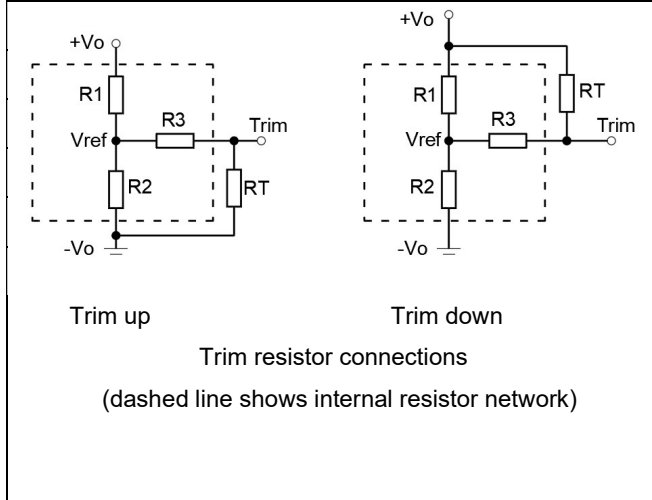

Figure 3

Model	Vin:24V
FUSE	Select according to the actual input current of the customer
EC1	1000µF/100V
EC2	470µF/100V
EC3	330µF/50V
C1, C2	4.7µF/100V
C3, C4	20µF/50V
LCM1	10mH MIN
LDM1	2.2uH
CY1/CY2	2.2nF/3000VDC

Trim Function for Output Voltage Adjustment(No connected if unused)



Vout(V)	R1(KΩ)	R2(KΩ)	R3(KΩ)	Vref(V)
5	2.4	2.344	13.622	2.5
12	8.2	2.153	17.346	2.5
15	12	2.388	21.016	2.5
24	10	1.158	10.714	2.5

$\text{Up : } R_t = \frac{nR_2}{R_2 - n} - R_3$ $\text{Down : } R_t = \frac{nR_1}{R_1 - n} - R_3$	$n = \frac{V_{ref}}{V_o - V_{ref}} * R_1$ $n = \frac{V_o - V_{ref}}{V_{ref}} * R_2$
---	---

Dimensions and Recommended Layout

ATB_LD-60WR3 Dimensions

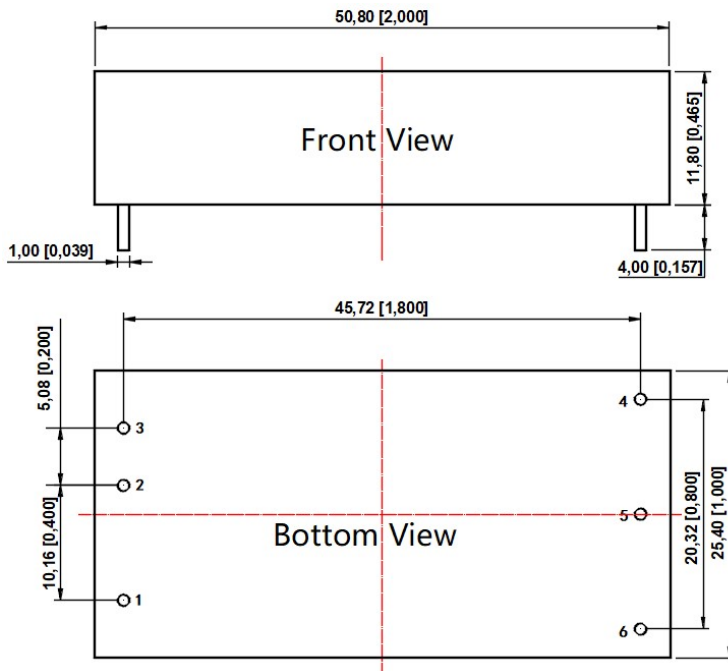

PCB Printing Layout & Pin Definition Table

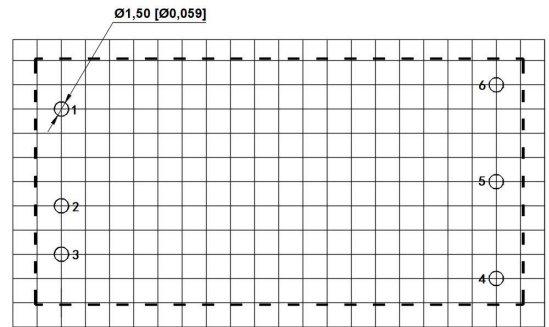

Note: The grid distance is 2.54*2.54mm

Pin	Function (Single)
1	Ctrl
2	GND
3	V _{in}
4	+V _o
5	-V _o
6	Trim

Note:

Unit: mm[inch]

Pin section tolerances: ±0.10[±0.004]

General tolerances: ±0.50[±0.020]

ATB_LD-60WR3A2S Dimensions

Pin Definition Table

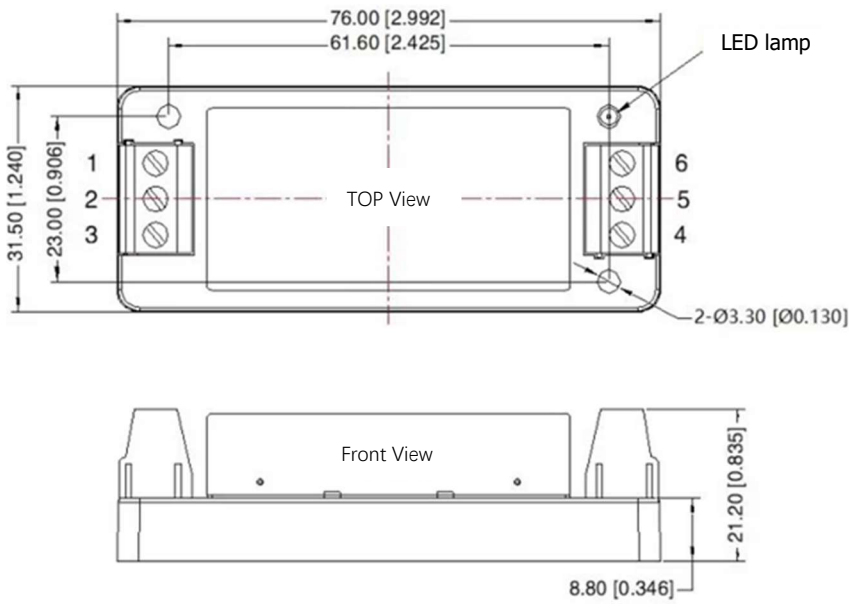

Pin	Function (Single)
1	Ctrl
2	GND
3	Vin
4	+Vo
5	-Vo
6	Trim

Note:

Unit: mm[inch]
 Wire range: 24-12 AWG
 Tightening torque: MAX 0.4N.m
 General tolerance: ±1.00[±0.039]

Note:

1. If the product works under the minimum required load, it cannot guarantee that the performance of the product complies with all the performance indicators in this manual;
2. The maximum capacitive load is tested under the input voltage range and full load condition;
3. Unless otherwise stated, all indexes in this manual are measured at Ta=25°C, humidity <75%RH, nominal input voltage and rated output load;
4. All index testing methods in this manual are based on the enterprise standards of the company;
5. Our company can provide product customization, specific needs can directly contact our technical staff;

DONGGUAN AMCHARD-POWER TECHNOLOGY CO., LTD.

www.amchard-power.com

Mail:info@amchard-power.com