

Product Feature

1. Package Type: SIP8
2. Operating Temperature Range: -40°C - +105°C
3. Isolation Voltage: 3000VDC
4. 2:1 Wide Input Voltage Range
5. High efficiency up to 83%
6. With the output overcurrent protection and output short circuit protection mechanism
7. Fields of application: industry, power, instrumentation, communication, rail transit, etc

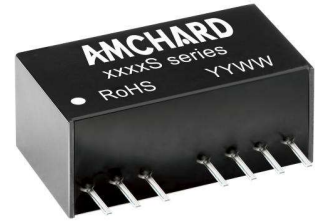

3 years Warranty

Selection Guide

Part No.	Input Voltage (VDC)		Output			Ripple & Noise (Typ./Max.) (mVp-p)	Full Load Efficiency% (Min./Typ.)	Capacitive Load Max. (µF)	
	Nominal (Range)	Voltage (VDC)	Current Max.(mA)	Current Min.(mA)					
BTF0503S-3WR2	5 (4.5-9)	3.3	758	38	40/75	67/69	1800		
BTF0505S-3WR2		5	500	25		72/74	2200		
BTF0512S-3WR2		12	208	10		76/78	680		
BTF0515S-3WR2		15	167	8		73/75	470		
BTF0524S-3WR2		24	104	5		75/77	330		
BTE0505S-3WR2		±5	±250	±13		73/75	#1000		
BTE0512S-3WR2		±12	±104	±5		76/78	#470		
BTE0515S-3WR2		±15	±83	±4		76/78	#330		
BTE0524S-3WR2		±24	±52	±3		75/77	#220		
BTF1203S-3WR2		12 (9-18)	3.3	758		38	100/150	74/76	2700
BTF1205S-3WR2	5		600	30	75/77	2200			
BTF1212S-3WR2	12		250	13	81/83	680			
BTF1215S-3WR2	15		200	10	82/84	470			
BTF1224S-3WR2	24		125	6	80/82	330			
BTE1205S-3WR2	±5		±300	±15	77/79	#1000			
BTE1212S-3WR2	±12		±125	±6	78/80	#470			
BTE1215S-3WR2	±15		±100	±5	79/81	#330			
BTF2403S-3WR2	24 (18-36)		3.3	758	38	40/75		72/75	2700
BTF2405S-3WR2			5	600	30			80/82	2200
BTF2412S-3WR2		12	250	13	82/84		680		
BTF2415S-3WR2		15	200	10	82/84		470		
BTF2424S-3WR2		24	125	6	82/84		330		
BTE2405S-3WR2		±5	±300	±15	78/80		#1000		
BTE2412S-3WR2		±12	±125	±6	82/84		#470		
BTE2415S-3WR2		±15	±100	±4	82/84		#330		
BTF4803S-3WR2		48 (36-75)	3.3	758	38		100/150	74/76	2700
BTF4805S-3WR2			5	600	30		40/75	75/77	2200
BTF4812S-3WR2	12		250	10	79/81	680			
BTF4815S-3WR2	15		200	10	83/85	470			

BTF4824S-3WR2		24	104	5	70/100	81/83	330
BTE4805S-3WR2		±5	±300	±15	40/75	78/80	#1000
BTE4812S-3WR2		±12	±125	±6		81/83	#470
BTE4815S-3WR2		±15	±100	±5		81/83	#330

each output

Input Specifications

Item	Operating Conditions	Min.	Typ.	Max.	Unit	
Input Current (full load/no load)	5VDC Input	--	800/60	846/65	mA	
	12VDC Input	3.3VDC Output	--	277/25		286/30
		Other Output	--	314/25		338/30
	24VDC Input	3.3VDC Output	--	140/8		145/13
		Other Output	--	154/8		163/13
	48VDC Input	3.3VDC Output	--	69/3		72/10
Other Output		--	78/3	85/10		
Reflected Ripple Current	5VDC Input	--	20	--	VDC	
	12VDC Input	--	20	--		
	24VDC Input	--	55	--		
	48VDC Input	--	55	--		
Impulse Voltage	5VDC Input	-0.7	--	12	VDC	
	12VDC Input	-0.7	--	25		
	24VDC Input	-0.7	--	50		
	48VDC Input	-0.7	--	100		
Starting Voltage	5VDC Input	3.5	4	4.5	VDC	
	12VDC Input	4.5	8	9		
	24VDC Input	11	16	18		
	48VDC Input	24	33	36		
Input Filter		Capacitance Filter				
Hot Plug		Unavailable				
CTRL	Module off	0-0.7V turn off				
	Module on	No connect or 3.5-12V on				

Output Specifications

Item	Operating Conditions	Min.	Typ.	Max.	Unit
Output Voltage Accuracy	5% - 100% Load	--	±1.0	±3.0	%
No-load Output Voltage Accuracy	Input Voltage Range	--	±1.5	±5.0	
Linear Regulation	Full load, Input voltage from low limit to high limit	--	±0.2	±0.5	
Load Regulation	5% - 100% Load	--	±0.4	±0.75	
Transient Recovery Time	25% load step change	--	0.5	3	ms
Transient Response Deviation		--	±2.5	±5	%

Temperature Coefficient	Full Load	--	±0.02	±0.03	%/°C
Ripple & Noise	20MHZ Bandwidth	See the selection guide for data			
Short-circuit Protection	Continuous, Self-Recovery				

General Specifications

Item	Operating Conditions	Min.	Typ.	Max.	Unit
Insulation Voltage	Input-output, test time 1 minute, leakage current less than 1mA	3000	--	--	VDC
Insulation Resistance	Input-output, insulated voltage 500VDC	1000	--	--	MΩ
Isolation Capacitance	Input-output, 100KHz/0.1V	--	30	50	pF
Operating Temperature	Derating when operating temperature ≥ 85°C, (See Figure 1)	-40	--	+85	°C
Storage Temperature		-55	--	+105	
Storage Humidity	Non-condensing	--	--	95	%RH
Pin welding can withstand the highest temperature	Soldering spot is 1.5mm away from case for 10 seconds	--	--	300	°C
Switching Frequency	Full Load, Nominal Input Voltage	150	208	300	kHz
MTBF	MIL-HDBK-217F@25°C	>1000Kh			

Mechanical Specifications

Case Material	Black plastic; flame-retardant and heat-resistant (UL 94V-0 rated)
Package Dimensions	22.00 * 12.00 * 9.50 mm
Weight	3.8g (Typ.)
Cooling Method	Free air convection

EMC Specifications

EMI	CE	CISPR32/EN55032 CLASS B (The recommended circuit is shown in Figure 3-②)	
	RE	CISPR32/EN55032 CLASS B (The recommended circuit is shown in Figure 3-②)	
EMS	ESD	IEC/EN61000-4-2 Contact ±4KV	perf.Criteria B
	RS	IEC/EN61000-4-3 10V/m	Perf.Criteria A
	EFT	IEC/EN61000-4-4 ±2KV (The recommended circuit is shown in Figure 3-①)	Perf.Criteria B
	Surge	IEC/EN61000-4-5 line to line ±2KV (The recommended circuit is shown in Figure 3-①)	Perf.Criteria B
	Cs	IEC/EN61000-4-6 3 Vr.m.s	Perf.Criteria A
	Voltage dips, DIPS and short interruptions	IEC/EN61000-4-29 0%, 70%	Perf.Criteria B

Typical Characteristic Curves

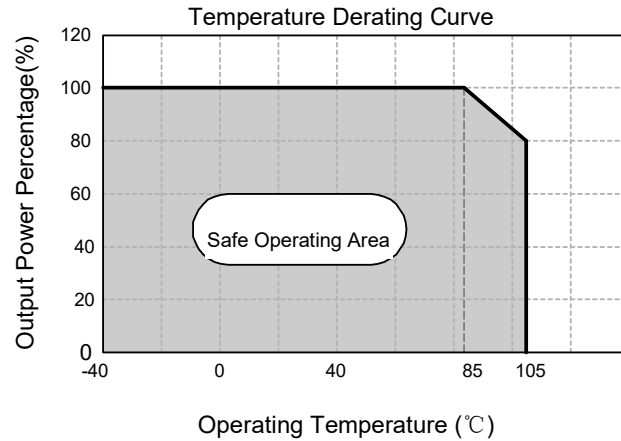
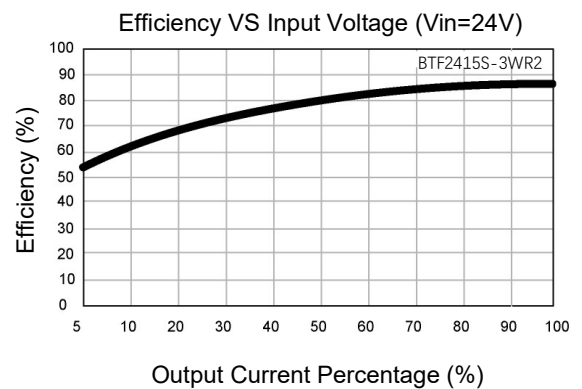
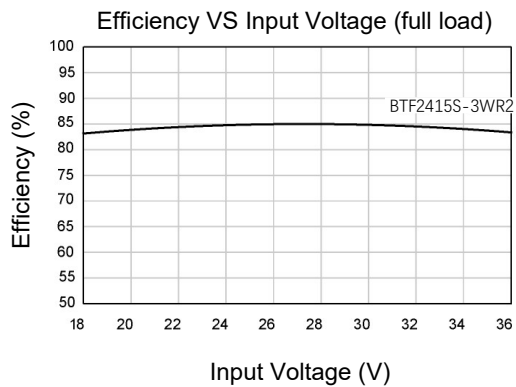
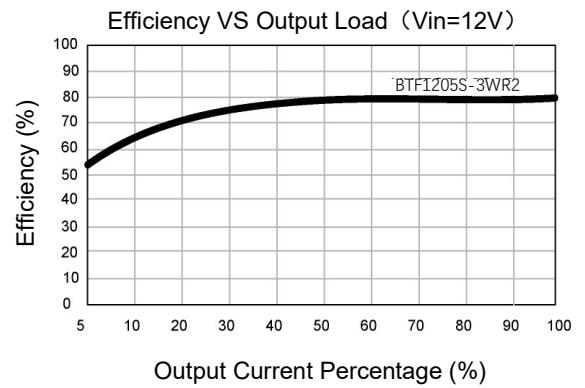
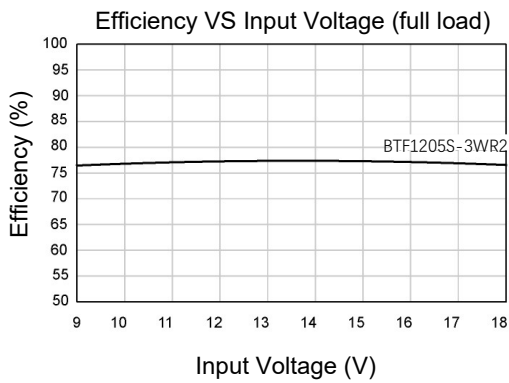
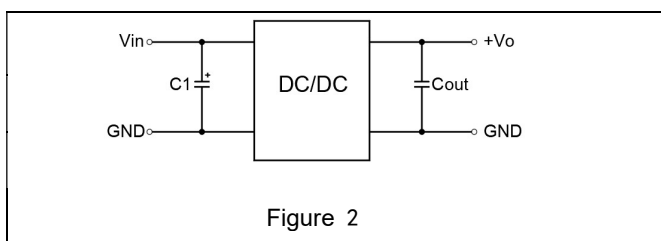

Figure 1



Circuit Design and Application



Recommended Capacitive Load Value Table	
Cin(μF)	Cout(μF)
100	22

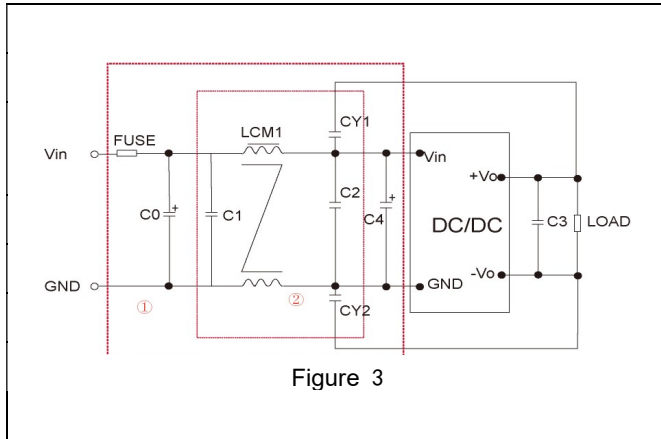

EMI Recommended Parameter Table		
Model	Vin:12V	Vin:24V
FUSE	Select according to the actual input current of the customer	
C0、C4	330uF/35V	330uF/50V
C1、C2	10μF/50V	
LCM1	1.4-1.7mH	
C3	22μF/50V	
CY1、CY2	1nF/400VAC	

Note: Part 1 in Figure 3 is for EMC testing; The second part is used for EMI filtering, which can be selected according to the demand.

Dimensions and Recommended Layout

Dimensions	PCB Printing Layout & Pin Definition Table
------------	--

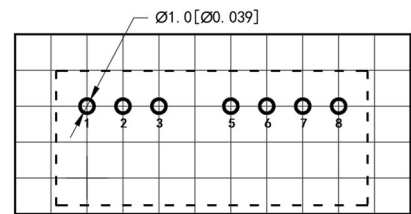
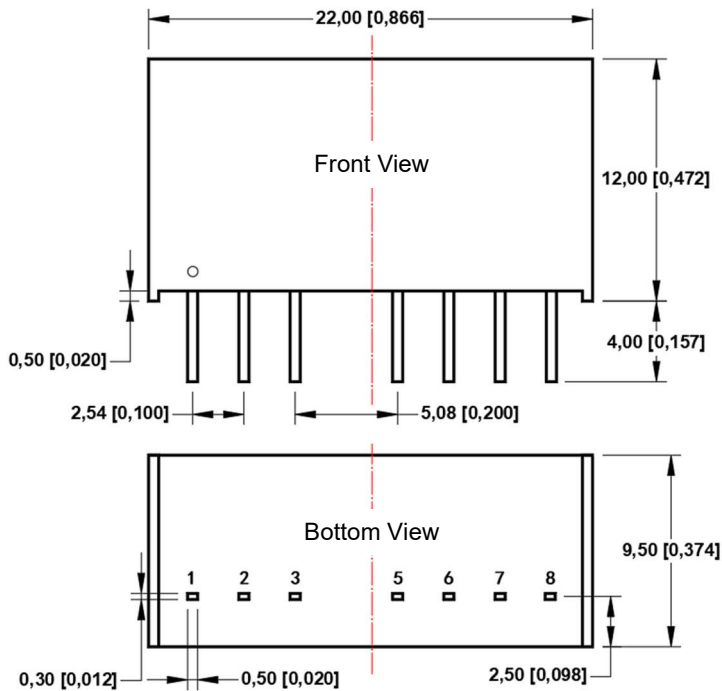

Note: The grid distance is 2.54mm*2.54mm

Pin	Function(single)	Function(double)
1	GND	GND
2	Vin	Vin
3	CTRL	CTRL
5	NC	NC
6	+Vo	+Vo
7	-Vo	COM
8	NC	-Vo

NC: Pin to be isolated from circuitry

Note:

Unit: mm[inch]

Pin section tolerances: ±0.10[±0.004]

General tolerances: ±0.50[±0.020]

Note:

1. The input voltage cannot exceed the specified range value, otherwise permanent and irreparable damage may be caused ;
2. Unless otherwise specified, the parameters in this datasheet were measured at 25°C, humidity 40%~75%, input nominal voltage and output pure resistance mode under full load;
3. All index test methods are based on our company's enterprise standards.

DONGGUAN AMCHARD-POWER TECHNOLOGY CO., LTD.

www.amchard-power.com

Mail: info@amchard-power.com