

Features

1. Wide operating temperature range: -40°C to +85°C
2. Up to 75% efficiency
3. No load current as low as 5mA
4. Ripple as low as 30mVp-p
5. Sustainable short-circuit protection
6. Isolation:3000VDC
7. Fixed voltage input, Output 1W, Isolated, Stabilized voltage, Single Output, SIP package.

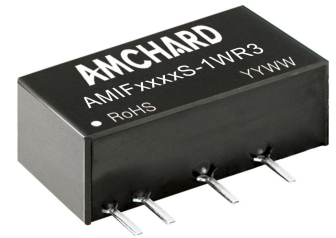

3 years
Warranty

Model Numbering

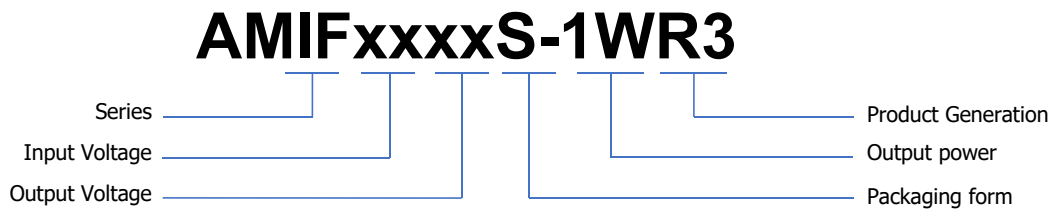

Selection Guide

产品型号 Product model	输入电压 Input Voltage Standard value(range)	输出电压 Output Voltage	输出电流 Output Current (mA) (Max./Min.)	效率 Efficiency % (Min./Typ.)	最大容性负载 Maximum capacitive load (μ F)
AMIF0303S-1WR3	3.3VDC (3.14-3.46)	3.3	250/30	63/70	2400
AMIF0305S-1WR3		5	200/20	66/75	2400
AMIF0309S-1WR3		9	111/12	66/71	1000
AMIF0312S-1WR3		12	84/9	66/72	560
AMIF0315S-1WR3		15	67/7	66/72	560
AMIF0324S-1WR3		24	42/4	66/72	220

产品型号 Product model	输入电压 Input Voltage Standard value(range)	输出电压 Output Voltage	输出电流 Output Current (mA) (Max./Min.)	效率 Efficiency % (Min./Typ.)	最大容性负载 Maximum capacitive load (μ F)
AMIF0503S-1WR3	5VDC (4.75-5.25)	3.3	250/30	63/70	2400
AMIF0505S-1WR3		5	200/20	66/75	2400
AMIF0509S-1WR3		9	111/12	66/71	1000
AMIF0512S-1WR3		12	84/9	66/72	560
AMIF0515S-1WR3		15	67/7	66/72	560
AMIF0524S-1WR3		24	42/4	66/72	220
AMIF0903S-1WR3	9VDC (8.55-9.45)	3.3	250/30	63/70	2400
AMIF0905S-1WR3		5	200/20	66/75	2400
AMIF0909S-1WR3		9	111/12	66/71	1000
AMIF0912S-1WR3		12	84/9	66/72	560
AMIF0915S-1WR3		15	67/7	66/72	560
AMIF0924S-1WR3		24	42/4	66/72	220
AMIF1203S-1WR3	12VDC (11.4-12.6)	3.3	250/30	63/70	2400
AMIF1205S-1WR3		5	200/20	66/75	2400
AMIF1209S-1WR3		9	111/12	66/71	1000
AMIF1212S-1WR3		12	84/9	66/72	560
AMIF1215S-1WR3		15	67/7	66/72	560
AMIF1224S-1WR3		24	42/4	66/72	220
AMIF1503S-1WR3	15VDC (14.25-15.75)	3.3	250/30	63/70	2400
AMIF1505S-1WR3		5	200/20	66/75	2400
AMIF1509S-1WR3		9	111/12	66/71	1000
AMIF1512S-1WR3		12	84/9	66/72	560
AMIF1515S-1WR3		15	67/7	66/72	560
AMIF1524S-1WR3		24	42/4	66/72	220
AMIF2403S-1WR3	24VDC (22.8-25.2)	3.3	250/30	63/70	2400
AMIF2405S-1WR3		5	200/20	66/75	2400
AMIF2409S-1WR3		9	111/12	66/71	1000
AMIF2412S-1WR3		12	84/9	66/72	560
AMIF2415S-1WR3		15	67/7	66/72	560
AMIF2424S-1WR3		24	42/4	66/72	220

Input Characteristics

Parameter/参数	Conditions/测试条件		Min.	Typ.	Max.	Units
Input current (Rated Load) 输入电流 (额定负载)	Nominal voltage input@3.3VDC 标称电压输入@3.3VDC	3.3VDC Output	--	390	410	mA
		5VDC/7.2VDC Output	--	380	400	mA
		9VDC/12VDC Output	--	375	390	mA
		15VDC/24VDC Output	--	360	385	mA
	Nominal voltage input@5VDC 标称电压输入@5VDC	3.3VDC Output	--	290	310	mA
		5VDC/7.2VDC Output	--	285	305	mA
		9VDC/12VDC Output	--	280	300	mA
		15VDC/24VDC Output	--	270	290	mA
	Nominal voltage input@12VDC 标称电压输入@12VDC	3.3VDC Output	--	125	130	mA
		5VDC/7.2VDC Output	--	115	120	mA
		9VDC/12VDC Output	--	113	120	mA
		15VDC/24VDC Output	--	110	120	mA
	Nominal voltage input@15VDC 标称电压输入@15VDC	3.3VDC Output	--	95	100	mA
		5VDC/7.2VDC Output	--	92	97	mA
		9VDC/12VDC Output	--	88	95	mA
		15VDC/24VDC Output	--	86	90	mA
	Nominal voltage input@24VDC 标称电压输入@24VDC	3.3VDC Output	--	59	65	mA
		5VDC/7.2VDC Output	--	58	64	mA
		9VDC/12VDC Output	--	57	64	mA
		15VDC/24VDC Output	--	56	63	mA
Input current (No-load) 输入电流 (空载)			--	5	20	mA
Reflected ripple current 反射纹波电流			3	15	20	mA
Input impulse voltage 输入冲击电压	1sec. max. 最大1秒	3.3VDC/5VDC Input	-0.7	--	7	VDC
		9VDC Input	-0.7	--	12	VDC
		12VDC Input	-0.7	--	18	VDC
		15VDC Input	-0.7	--	21	VDC
		24VDC Input	-0.7	--	30	VDC
Input filter 输入滤波类型	Capacitive filtering 电容滤波					
Remarks/备注: This product does not support hot plug / 此产品不支持热插拔						

Output Characteristic

Parameter/参数	Conditions/测试条件	Min.	Typ.	Max.	Units	
Output voltage accuracy 输出电压精度				+/-3	%	
Linear regulation rate 线性调节率	Input voltage variation +/- 1% 输入电压变化 +/-1%	3.3VDC Output	--	--	+/-0.3	%
		Other outputs	--	--	+/-0.25	%
Load regulation rate 负载调节率	10% to 100% load 10%-100% 负载	3.3VDC Output	--	1	3	%
		5VDC Output	--	1	2	%
		9VDC Output	--	1	2	%
		12VDC Output	--	1	2	%
		15VDC Output	--	1	2	%
		24VDC Output	--	1	2	%
Ripple & Noise 波纹和噪声	20MHz bandwidth 20MHz带宽	--	30	100	mVp-p	
Temperature drift coefficient 温度漂移系数	100% load 满载	--	+/-0.03	--	%/°C	
Short circuit protection 短路保护	Sustainable, Self-healing 可持续、自恢复					

Note: The testing method for ripple and noise is the parallel line testing method.
注：纹波和噪声的测试方法采用平行线测试法。

General Characteristics

Parameter/参数	Conditions/测试条件	Min.	Typ.	Max.	Units
Isolation voltage 隔离电压	Input-output, Test time 1 minute, Leakage current less than 1 mA 输入-输出, 测试时间1分钟, 漏电流小于1 mA	3000	--	--	VDC
Insulation resistance 绝缘电阻	Input-output, Insulation voltage 500VDC 输入-输出, 绝缘电压500VDC	1000	--	--	MΩ
Isolation capacitance 隔离电容	Input-output, 100KHz/0.1V 输入-输出, 100KHz/0.1V	--	20	50	pF
Working temperature 工作温度	Temperature ≥ 85 °C for derating (See Figure 4) 温度 ≥85°C时, 降额使用 (见图4)	-40	--	+85	°C
Storage temperature 储存温度		-55	--	+125	°C
Storage humidity 储存湿度	Non condensing 无凝结	--	--	95	%RH

Parameter/参数	Conditions/测试条件	Min.	Typ.	Max.	Units
Housing temperature rise during operation 工作时外壳温升	Ta=25 °C, Nominal input, Full output Ta=25°C, 标称电压输入, 满载	--	15	25	°C
Soldering temperature resistance of pins 引脚耐焊接温度	The distance from the welding spot to the shell is 1.5mm, 10 seconds 焊点到壳体的距离为1.5mm, 10秒	--	--	300	°C
	REFLOW: Peak temperature Tc ≤ 245 °C, maximum time above 217 °C for 60 seconds.(B_XT series) 回流焊: 峰值温度 Tc≤245°C, 217°C以上时间最大为60s.(B_XT系列)	--	--	245	°C
Switching frequency 开关频率	Full load, Nominal input voltage 满载, 标称输入电压	100	270	--	kHz
Mean time between failures 【MTBF】 平均无故障时间	MIL-HDBK-217F@25°C	3500	--	--	kHours

Physical Characteristics

Parameter/参数	Content/内容
Housing material 外壳材料	Black flame retardant and heat-resistant plastic (UL94V-0) 黑色阻燃耐热塑料 (UL94V-0)
Overall dimensions 外形尺寸	19.65 x7.05x 10.16mm
Weight 重量	2.4g(Typ.)
Cooling mode 冷却方式	Natural air cooling 自然空冷

EMC Characteristics

Parameter 参数	Category 类别	Content 内容
EMI	Conductive disturbance 传导骚扰	CISPR32/EN55032 CLASS B (The recommended circuit is shown in Figure 2) (推荐电路如图2所示)
	Radiation disturbance 辐射骚扰	CISPR32/EN55032 CLASS B (The recommended circuit is shown in Figure 2) (推荐电路如图2所示)
EMS	Electrostatic discharge 静电放电	IEC/EN61000-4-2 Contact ±4KV perf. Criteria B

Circuit Design and Application

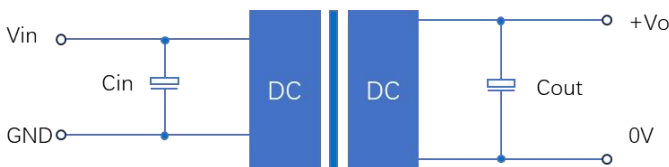

Figure 1: Application circuit

图1: 应用电路

Table 1:
Recommended Capacitive Load Values
推荐电容负载值

Vin(VDC)	Cin(μF)	Vo(VDC)	Cout(μF)
Nominal voltage 标称电压	1-10	Nominal voltage 标称电压	2.2-22

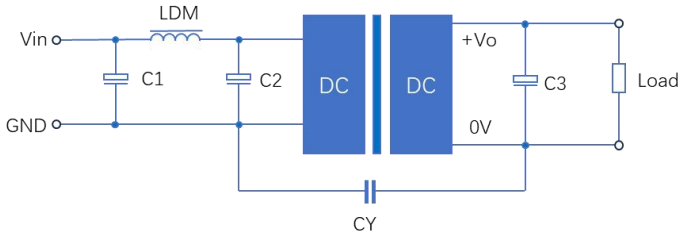

Figure 2: EMC Typical Recommended Circuits
图2:EMC典型推荐电路

Table 2:
Recommended Circuit Parameter Values
推荐电路参数

Category 类别	Component 元件	Value 参数
EMI	C1	4.7μF /50V
	C2	4.7μF /50V
	C3	2.2-22μF /50V
	CY	270pF/2kV
	LDM	6.8μH

1. Typical application: If further reduction of input and output ripple is required, a capacitor filter network can be connected at the input and output ends. The application circuit is shown in Figure 1. However, suitable filter capacitors should be selected. If the capacitance is too large, it may cause overcurrent or poor startup of the power supply. For each output, while ensuring safe and reliable operation, the recommended capacitance load values are shown in Table 1.
2. EMC requirements: For situations with high EMC requirements, a typical EMC recommended circuit is shown in Figure 2.
3. Input requirements: Ensure that the fluctuation range of the input voltage does not exceed the upper and lower limits of the input voltage specified in this data sheet, and the input power must be greater than the output power specified in this data sheet. For situations with a 24V input voltage, it is recommended to connect a TVS tube between the positive and negative input pins for protection (recommended parameters for TVS tubes: 30V, bidirectional, SOD-123 packaging).
4. Output load requirements: Try to avoid using it without load as much as possible; When the actual power of the load is less than 10% of the rated output power in this data sheet, or when it needs to be used in no-load situations, it is recommended to connect a load resistor externally at the output end. The load resistor can be calculated according to 5-10% of the rated power in this data sheet. The calculation formula for the load resistor value is $R_L = U_{out}^2 / (P_{out} * 10\%)$.
5. Overload protection: Under normal working conditions, the output circuit of this product has no protection function for overload situations. The simplest method is to connect a self recovery fuse in series at the input end, or add a circuit breaker outside the circuit; Or during design and selection, the actual power of the circuit should be around 60-80% of the rated power in this data sheet.

1. 典型应用：如果需要进一步降低输入和输出纹波，可以在输入和输出端连接电容滤波器网络。应用电路如图1所示。但是，应选择合适的滤波电容器。如果电容过大，可能会导致电源启动过流或启动不良。对于每个输出，在确保安全可靠运行的情况下，推荐的电容负载值如表1所示。
2. EMC要求：对于EMC要求较高的场合，典型的EMC推荐电路如图2所示。
3. 输入要求：确保输入电压波动范围不要超出本数据表的输入电压的上限和下限要求，输入功率必须大于本数据表中的输出功率。对于24V输入电压的场合，建议在输入正引脚和输入负引脚之间外接一个TVS管进行保护（TVS管推荐参数：30V,双向, SOD-123封装）。
4. 输出负载要求：应尽量避免空载使用；当负载的实际功率小于本数据表的额定输出功率的10%时，或需要在空载场合使用时，建议在输出端外接负载电阻，负载电阻可按照本数据表额定功率的5-10%计算，负载电阻值计算公式： $R_L = U_{out}^2 / (P_{out} * 10\%)$ 。
5. 过载保护：在通常工作条件下，该产品输出电路对于过载情况无保护功能，最简单的方法是在输入端串接一个自恢复保险丝，或在电路中外加一个断路器；或在设计选型时，电路的实际功率在本数据表额定功率的60-80%左右。

Product Characteristic Curve

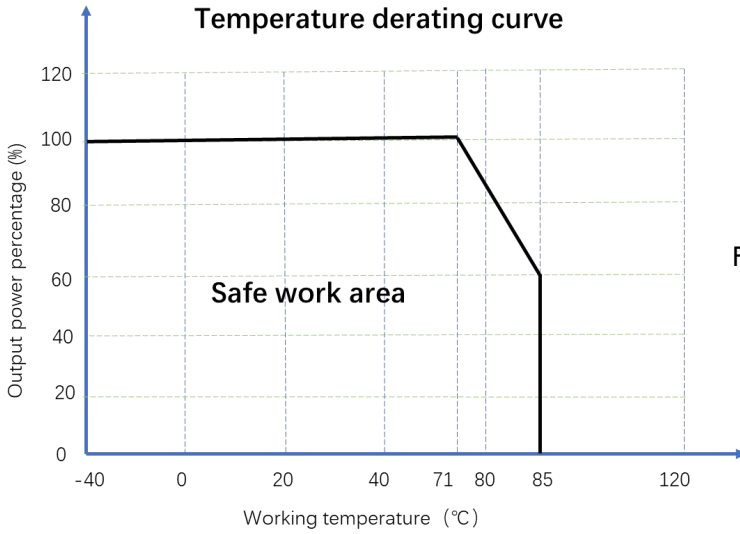

Figure 4: Temperature Derating Curve
图4: 温度降额曲线

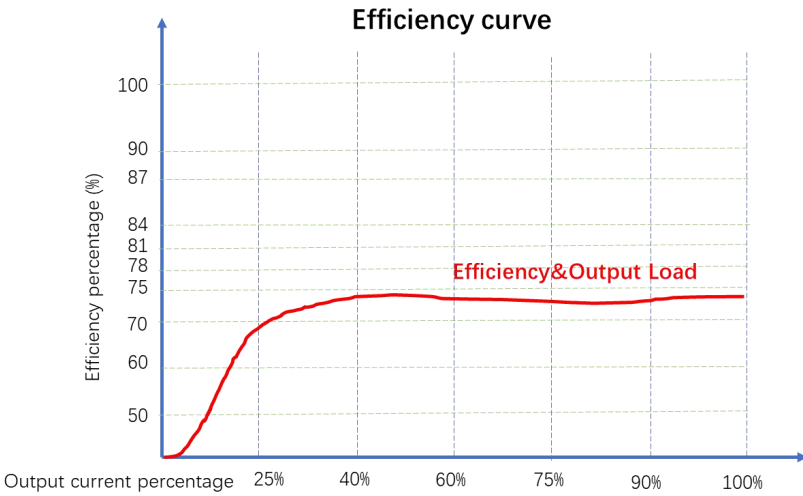

Figure 5: Efficiency VS Output Load (Nominal Voltage Input)
图5: 效率与输出负载 (标称电压输入)

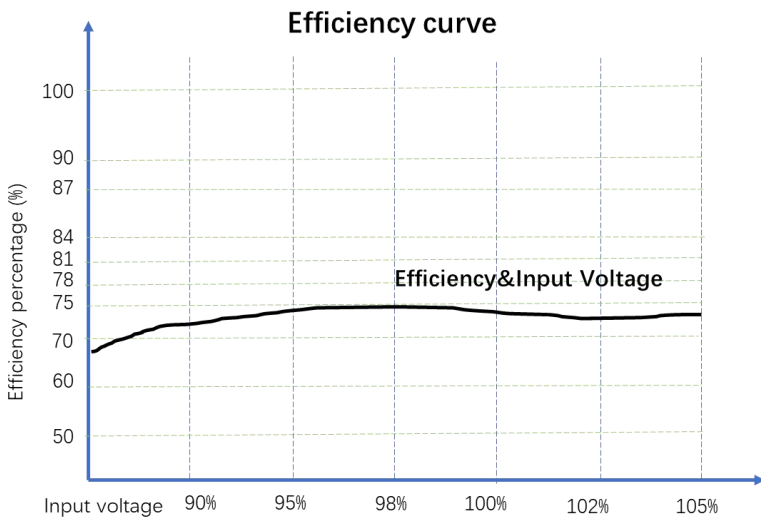

Figure 6: Efficiency VS Input Voltage (100% Load)
图6: 效率与输入电压 (100%负载)

Overall Dimensions and Pin Functions

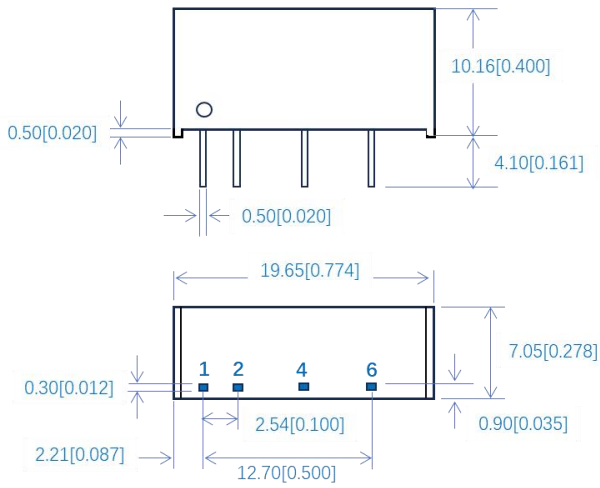
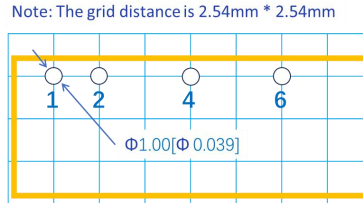

Figure 7: Overall dimensions
图7: 外形尺寸

Table 3: Pin Function Table /引脚功能表

Pin	Function
1	Vin
2	GND
4	0V
5	No pin
6	+Vo



Note:
Dimensions in mm[inch]
Terminal diameter tolerance: +/-0.10mm
Undeclared tolerance: +/-0.50mm

注: 尺寸单位为毫米[英寸]
端子直径公差: +/-0.10mm
未注公差: +/-0.50mm

Packaging Method

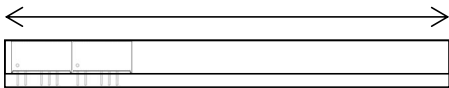

18 Pieces/Tube
18PCS/管

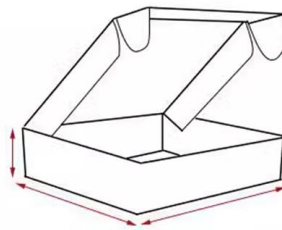

900 Pieces/Inner box
900 PCS/内盒

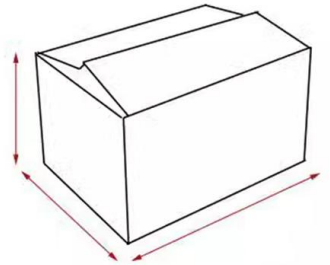

4500 Pieces/Outer box
4500 PCS/外箱

Notes & Instructions

1. The input voltage shall not exceed the specified range value, otherwise permanent and unrecoverable damage may be caused;
2. Unless otherwise specified, the parameters in this manual are measured at 25 °C, 40%~75% humidity, input nominal voltage and output pure resistance mode under full load;
3. All index test methods are based on the company's enterprise standards.
4. The copyright and the final interpretation right of the product belong to AMCHARD.

DONGGUAN AMCHARD-POWER TECHNOLOGY CO., LTD.

www.amchard-power.com

Mail:info@amchard-power.com