

Product Feature

1. Universal Input: 85-305VAC / 100-430VDC
2. Operating temperature range: -40°C - +85°C
3. Isolation:4000VAC
4. The mechanism has input undervoltage protection, output short circuit protection and over current protection
5. Design meet IEC/EN61558、IEC/EN60335

**3 years
Warranty**
Selection Guide

Part No.	Input Voltage (VAC)	Out Power (W)	Out Voltage (VDC)	Out Current (mA)MAX	Full Load Efficiency % (Typ.)	Capacitive Load(μF) Max.
QO05-13B03R3	85-305	5	3.3	1000	73	1500
QO05-13B05R3		5	5	1000	76	1500
QO05-13B12R3		5	12	420	78	470
QO05-13B15R3		5	15	340	79	330
QO05-13B24R3		5	24	210	81	100

Input Specifications

Item	Operating Conditions	Min.	Typ.	Max.	Unit
Input Voltage	AC Input	85	--	305	VAC
	DC Input	100	--	430	VDC
Input Current	110VAC	--	0.10	--	A
	230VAC	--	0.07	--	
Input Frequency		47	--	63	Hz
Fuse		1A, slow-blow, required			
Hot Plug		Unavailable			

Output Specifications

Item	Operating Conditions	Min.	Typ.	Max.	Unit
Output Voltage Accuracy	10% - 100%load	--	±5	--	%
Linear Regulation	Rated load	3.3V	±2.5	--	
		Other	±1.5	--	
Load Regulation	10% - 100%load	--	±3.0	--	
Ripple & Noise	20MHz bandwidth, 10% - 100%load	--	80	180	mV
Temperature Coefficient		--	±0.15	--	%/°C

Stand-by Power Consumption	230VAC	--	0.10	--	W
Min. Load		10	--	--	%
Over Current Protection		110	--	--	%Io
Short-Circuit Protection		Continuous, Self-Recovery			
Hold-up Time	115VAC	--	8	--	ms
	230VAC	--	40	--	

General Specifications

Item	Operating Conditions	Min.	Typ.	Max.	Unit
Isolation Voltage	Input-output, test time 1 minute, leakage current less than 5mA	4000	--	--	VAC
Insulation Resistance	Input-output, insulated voltage 500VDC	1000	--	--	MΩ
Power Derating	+55°C - +85°C	1.67	--	--	%°C
	85VAC - 100VAC	1.33	--	--	
Operating Temperature		-40	--	+85	°C
Storage Temperature		-40	--	+105	
Soldering Profile	Wave-soldering	260 ± 5°C; time: 5 - 10s			
	Manual-welding	360 ± 8°C; time: 3 - 5s			
Safety Standard	IEC/UL62368-1、IEC/EN60335-1、IEC/EN61558-1				
Safety Class		CLASS II			
MTBF	MIL-HDBK-217F@25°C	>1000Kh			

Mechanical Specification

Package Dimensions	26.40 x 17.6 x 11.00 mm
Weight	5.9g (TYP.)
Cooling Method	Free air convection

EMC Specifications

EMI	CE	CISPR32/EN55032 CLASS A (application circuit1, 4)			
		CISPR32/EN55032 CLASS B (application circuit2, 3)			
	RE	CISPR32/EN55032 CLASS A (application circuit1, 4)			
		CISPR32/EN55032 CLASS B (application circuit2, 3)			
EMS	RS	IEC/EN61000-4-3 10V/m			perf. Criteria A
	EFT	IEC/EN61000-4-4 ±2KV (application circuit 1、2)			perf. Criteria B

	IEC/EN61000-4-4 ±4KV (application circuit 3、4)	perf. Criteria B
Surge	IEC/EN61000-4-5 line to line ±1KV (application circuit 1、2)	perf. Criteria B
	IEC/EN61000-4-5 line to line ±2KV (application circuit 3、4)	perf. Criteria B
CS	IEC/EN61000-4-6 10Vr.m.s	perf. Criteria A
ESD	IEC/EN61000-4-2 Contact ±6KV / Air ±8KV	perf. Criteria B

Typical Characteristic Curves

Input voltage Derating Curve

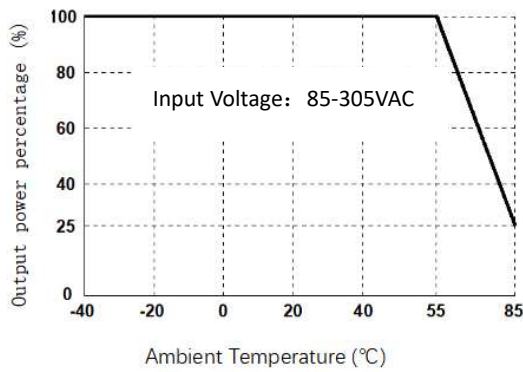

Temperature Derating Curve

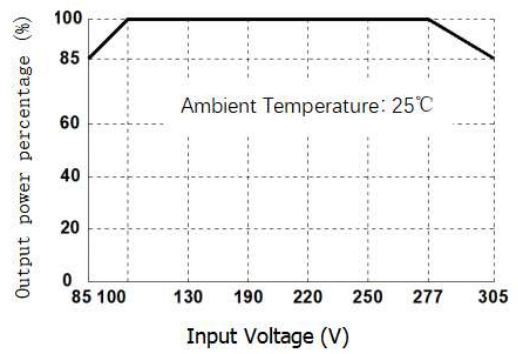

Efficiency VS Input Voltage (Full Load)

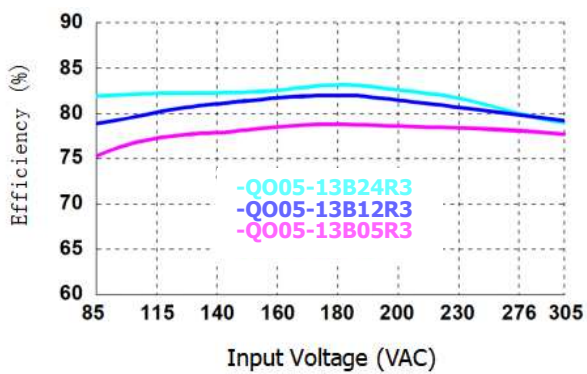

Efficiency VS Output Load (Vin=230VAC)

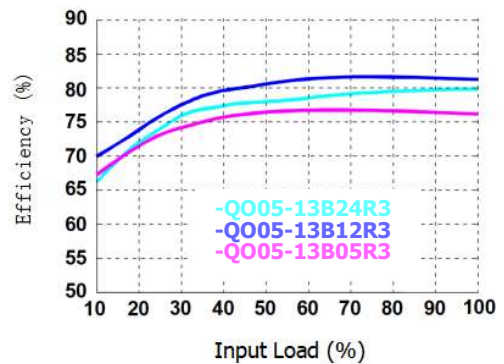

Typical Circuit Design And Application

Application circuit

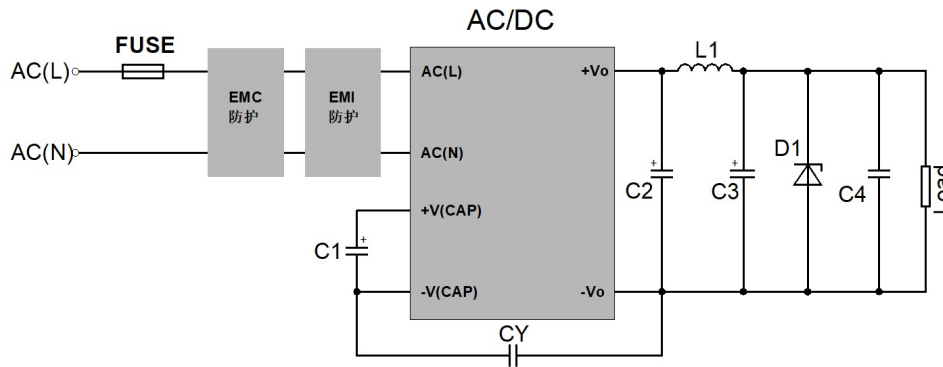

Reference Table for Selection of Peripheral Devices

Output voltage	C1 (required)	C2 (required)	L1 (required)	C3 (required)	C4	CY (required)	D1
5VDC	10uF/450V	560uF/16V	2.2uH 3A 40mΩMAX	100uF/16V	0.1uF/50V	1nF/400VAC	D1 is a TVS transistor that can protect the downstream circuit in case of module abnormalities. It is recommended to choose a model that is 1.2 times the output voltage
9/12VDC	10uF/450V	330uF/25V	2.2uH 3A 40mΩMAX	100uF/25V	0.1uF/50V	1nF/400VAC	
15/24VDC	10uF/450V	330uF/35V	3.3uH 2A 40mΩMAX	47uF/35V	0.1uF/50V	1nF/400VAC	

Note:

1. FUSE, EMC protection, and EMI protection are selected based on actual application needs;
2. C1 is a filtering electrolytic capacitor, which is a required component. It is recommended to use ripple current > 400mA@100KHz Electrolytic capacitors.
3. C2, C4, and L1 form a Pi type filtering circuit, and it is recommended to use high-frequency low resistance electrolytic capacitors or solid-state capacitors.
4. When selecting L1, ripple requirements can be considered, while paying attention to current and internal resistance values.

EMS Solutions - Recommended Circuits

Environmental Application - EMC Solution Selection Table

Recommended circuit	Application environment	Application industry	Input Voltage	Ambient Temperature	EMI	EMS
1	Basic applications	-	85-305VAC	-40°C - +85°C	Class A	III level
2	Indoor civil	Intelligent household electrical appliance		-25°C - +55°C	Class B	III level
	Indoor ordinary	Intelligent building		-25°C - +55°C	Class B	III level
3	Outdoor industry	Manufacturing workshop		-25°C - +55°C	Class B	IV level
4	Outdoor ordinary	ITS/Charging point/Communication/Security and protection		-40°C - +85°C	Class A	IV level

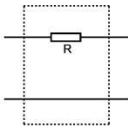
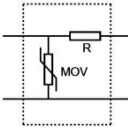
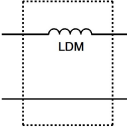
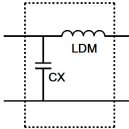
EMS protection circuit design reference		EMI protection circuit design reference	
III level	IV level	Class A	Class B
			

EMC Solutions - Recommended Circuits

Recommended circuit 1	Recommended circuit 2
-----------------------	-----------------------

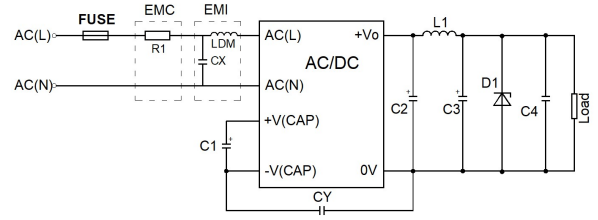
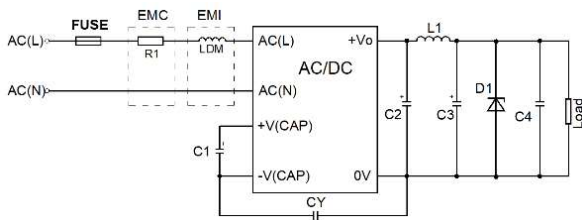

Recommended circuit 3	Recommended circuit 4
-----------------------	-----------------------

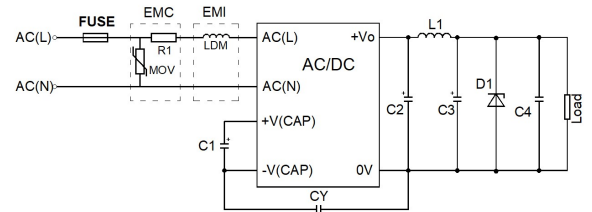
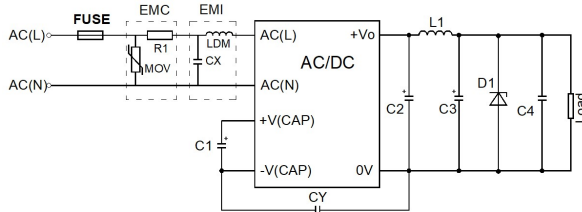

EMC Recommended Circuit Device Selection Reference Table				
Components	Recommended circuit 1	Recommended circuit 2	Recommended circuit 3	Recommended circuit 4
FUSE (required)	1A/300V, Slow melting		2A/300V, Slow melting	
Re1(wire-wound resistor, required)	12Ω/3W			
MOV	14D561			
LDM	2.2mH/Max: 4Ω/Min:0.24A			
CX	0.1uF/310VAC			

Dimensions and Recommended Layout

Dimensions

Note:

Unit: mm[inch]

Pin section tolerances: $\pm 0.10[\pm 0.004]$

General tolerances: $\pm 0.50[\pm 0.020]$

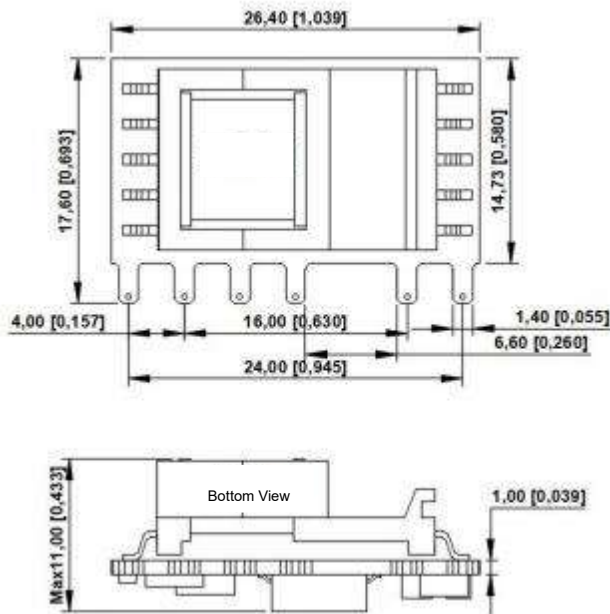

PCB Printing Layout

Grid size: 2.54 x 2.54 mm

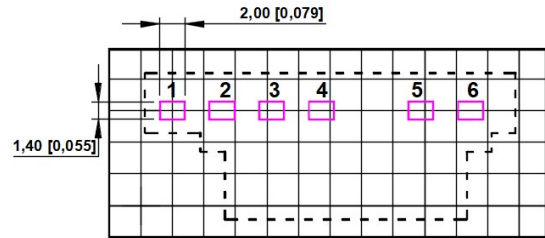

注: 栅格距离尺寸 2.54mm*2.54mm

Pin Function Table

Pin	Function
1	AC(L)
2	AC(N)
3	+V(CAP)
4	-V(CAP)
5	-Vo
6	+Vo

Note:

1. The input voltage cannot exceed the specified range value, otherwise permanent and irreparable damage may be caused;
2. Unless otherwise specified, the parameters in this datasheet were measured at 25°C, humidity 40%~75%, input nominal voltage and output pure resistance mode under full load;
3. All index test methods are based on our company's enterprise standards.

DONGGUAN AMCHARD-POWER TECHNOLOGY CO., LTD.

www.amchard-power.com

Mail: info@amchard-power.com